

The background of the image shows a complex industrial environment with various pieces of machinery, pipes, and electrical components. A semi-transparent blue vertical bar is positioned on the left side of the image, serving as a design element. The overall scene is brightly lit, highlighting the metallic and painted surfaces of the equipment.

REO

DRIVES

# ALL FROM ONE

From the choke to the braking resistor -  
Suitable components for your drive technology.



**Chokes**



**EMC-Filter**



**Braking resistors**



**Current and voltage sensors**



**HF-components**

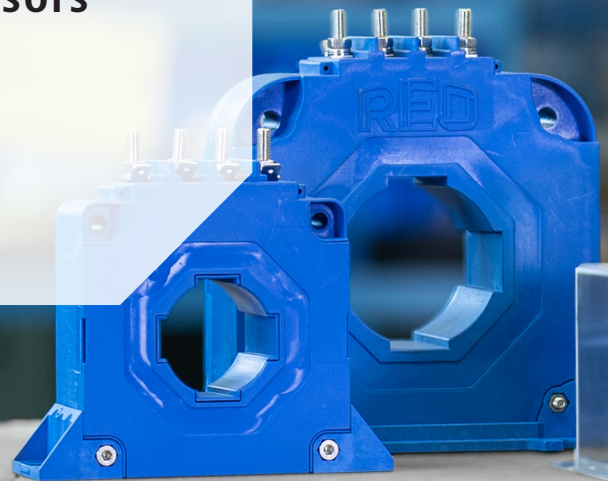

You can find more information at:  
**[www.drives.reo.de](http://www.drives.reo.de)**

# SOURCE!



## From standard product to individual solution!

REO is not just involved in mass production, but is instead focused on the development and production of specialist niche solutions in house. By working in close collaboration with our customers, we come up with ideas and technical solutions produced in small or large scale that can fit into an entire system and undertake tasks that cannot be covered by standard products available on the market. This means our customers can make use of the very latest applications and innovative production processes without having to resort to standard products and their associated limitations.

**Contact us:** Phone: 0212 8804-0 • Mail: [info@reo.de](mailto:info@reo.de)

# Catalogue overview

Chokes	S. 5-48
EMC-Filter	S. 49-64
Braking resistors	S. 65-90
Current and voltage sensors	S. 91-124
HF-components	S. 125-135



RED

## Chokes

# Chokes

Useful facts	P. 7-10
N CNW 901	P. 12-13
N CNW 903	P. 14-17
N CNW 905	P. 18-21
CNW 891	P. 22-23
N CNW 892	P. 24-25
N CNW 806	P. 26-29
CNW M 833	P. 30-31
N CNW 854	P. 32-35
CNW M 854	P. 36-37
CNW 931	P. 38-39
N CNW 933	P. 40-43
CNW M 933	P. 44-45
CNW 961	P. 46-47

# Useful facts about chokes

Modules for drive technology - Input components

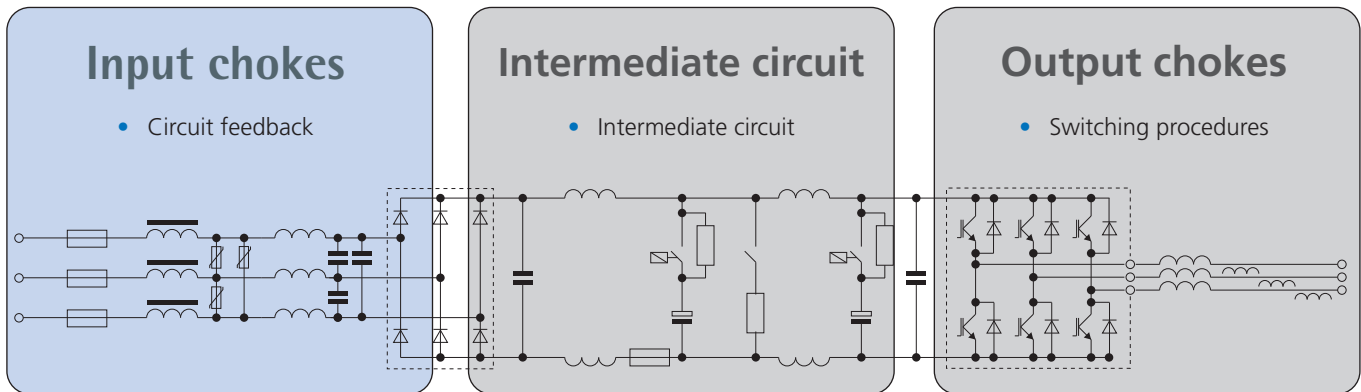

## Mains chokes

Mains disturbances, such as voltage dips and current peaks, can severely interfere with electronic control systems and have a negative influence on them. They are caused by switching operations or earth faults as well as start-up and switch-on processes in the supply network. The line choke can limit the effect of these disturbances.

## $U_k$ -value [%]

The voltage drop along the choke can be described using the  $U_k$  value of the line choke. REOWAVE offers a standard series with 1%, 2% and 4%  $U_k$ .

## Series

- N CNW 903 / I [A] mit 4%  $U_k$
- N CNW 905 / I [A] mit 2%  $U_k$

## Advantages of line chokes

- Damping of very high current peaks by up to 40%.
- Minimization of deformation of sinusoidal mains voltage to trapezoidal voltage
- Relief of the supply network by compensation of the harmonics reactive power
- The harmonics are greatly reduced.

Properties of the input components			
Assessment of the effects of input chokes and filters:	N CNW 905	N CNW 903	REOWAVE@passive CNW 8981
Limitation of starting currents	good	very good	optimal
Damping of current peaks	good	very good	optimal
Compensation of harmonic reactive power	good	very good	optimal
Improvement THD	good	very good	optimal
Operation with common mode interference possible	no	no	no
Improvement energy efficiency	good	very good	optimal
Improvement of the overall efficiency of the system	good	very good	optimal
Compliance with power quality standards IEEE 519 or EN 61000-3	no	no	yes

With these standard series, the following nominal voltage drops are obtained in the networks for Europe and America:

Europe			
$U_k$	Nominal frequency [Hz]	Nominal voltage [V]	Voltage drop [V]
4%	50	400	9,2
2%			4,6
1%			2,3

America			
$U_k$	Nominal frequency [Hz]	Nominal voltage [V]	Voltage drop [V]
4%	60	400	11,1
2%			5,5
1%			2,8

# Useful facts about chokes

Modules for drive technology - Intermediate circuit components

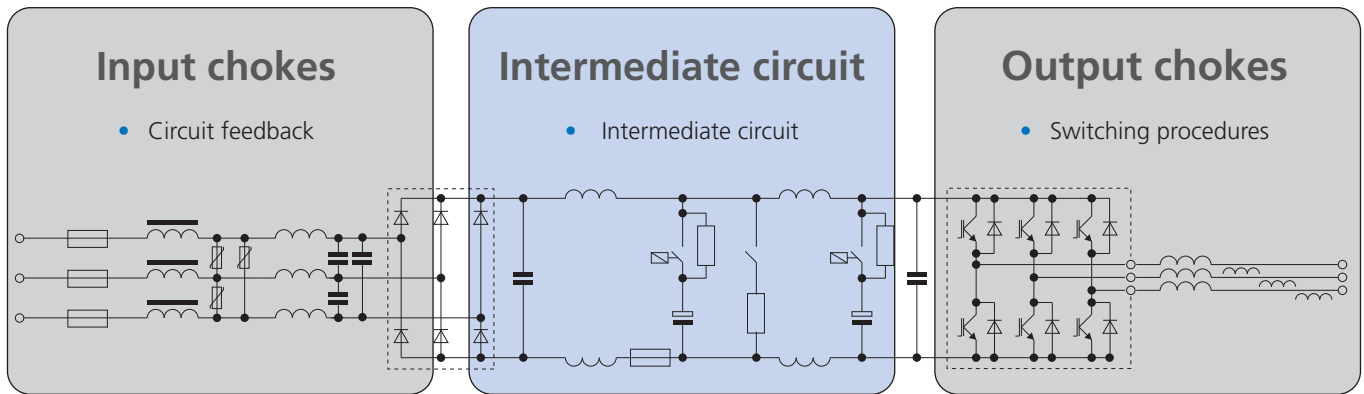

## DC-Link chokes

The typical power supply combinations of rectifiers and capacitors put considerable strain on the supply network. Depending on the function, the current consumption of the power supply units or inverters at the moment of maximum voltage is not sinusoidal, but pulsed. The intermediate circuit choke serves as a passive component similar to the line choke to reduce harmonics and relieve the supply network. In addition, the intermediate circuit choke attenuates the charging current peak of the intermediate circuit capacitors. The field of application can be found in frequency converters for drive technology, in general DC power supplies and in alternative energy generation.

Improvement of the efficiency of an inverter (Power Factor Correction): Starting currents and current peaks are damped up to 70 %. Intermediate circuit chokes help to comply with the international PowerQuality standards IEEE 519 or EN 61000-3-2.

### Advantages DC-Link chokes

- Reduction of harmonic waves
- Damping of current peaks up to 70 %
- Compact design
- Advantages compared to the line choke: Smaller size, lower material cost/price, lower power dissipation
- Production according to UL insulation system E251513 possible

Comparison of inverter operation without and with DC-Link chokes	
without DC-Link chokes	with DC-Link chokes CNW 891/10
CH 1: Voltage, CH 2: Current	CH 1: Voltage, CH 2: Current
Effective current: 14,5 A	Effective current: 9,34 A
Peak current: 38,0 A	Peak current: 16,0 A
Apparent power from the mains: 9,73 kW	Apparent power from the mains: 6,51 kW
Performance factor: 0,60	Performance factor: 0,93

The use of an intermediate circuit choke improves the power factor to 0.93 and reduces the effective current to 66.5%.



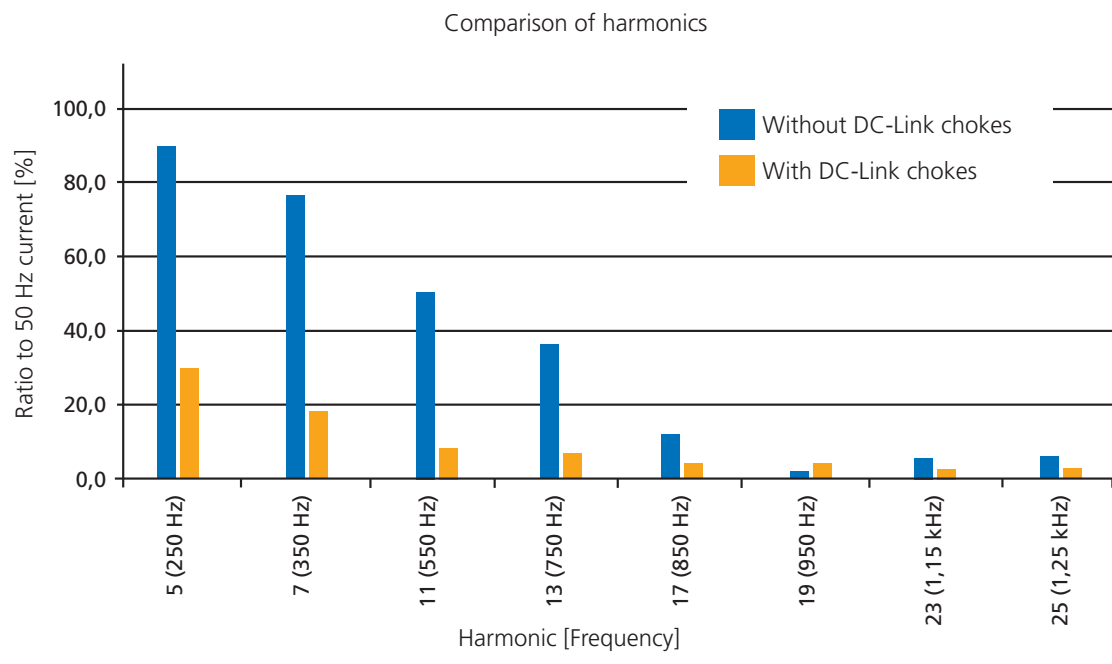

A clear decrease in harmonics can be seen. An intermediate circuit choke reduces the harmonic reactive power load on the supply network.

## Useful facts about chokes

Modules for drive technology - output components

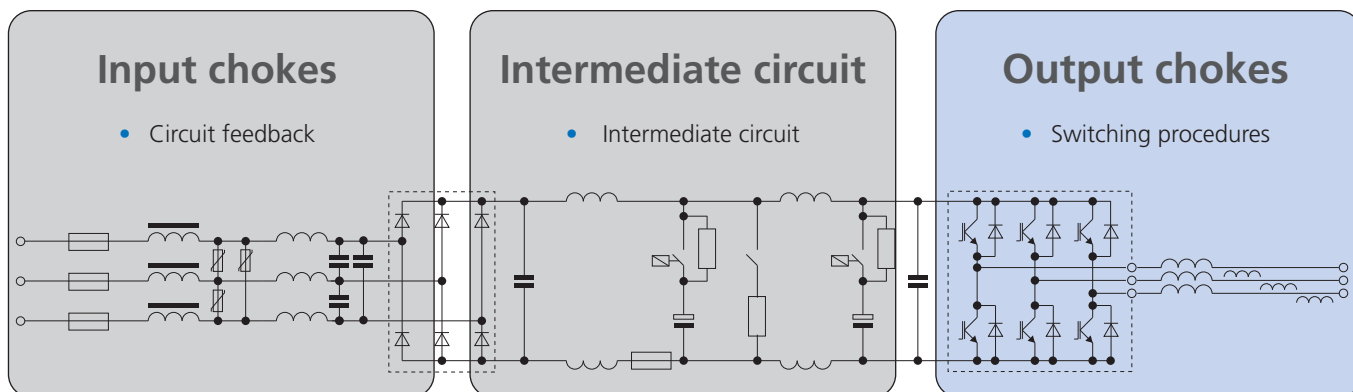

### Output chokes

One of the advantages of modern frequency converters is that high switching frequencies increase the control accuracy and the components are able to be smaller. Every fast switching pulse of the power semiconductors in the frequency converter causes a very steep DV/DT rise and correspondingly high current peaks, which are harmful for the motor insulation. Another disadvantage of the high switching frequency is the pronounced EMC problem.

### Advantages of output chokes

- Protection for electrical loads
- Limitation of voltage rise to  $< 200 \text{ V}/\mu\text{s}$
- Extended service life for electrical loads
- Reduction of audible motor noise
- Low leakage currents at the motor
- Longer motor cables possible
- Easy assembly
- Compact design
- Production according to UL insulation system E251513 possible

Properties of our output components			
Assessment of the effects of output chokes and filters on:	N CNW 806	N CNW 854	N CNW 933
Limiting the voltage rise	good	very good	Like mains operation
Avoidance of transient overvoltages	good	very good	Like mains operation
Compensation of capacitive charging currents	moderate	good	Like mains operation
Damping of motor noises	none	moderate	very good
Optimization of motor losses	none	moderate	very good
Operation with common mode interference possible	none	none	none
Damping of the EMC radiation of the motor supply cable	none	moderate	good
Reduction of bearing currents	none	none	none
Improvement of the overall efficiency of the system	moderate	good	very good



# N CNW 901

Single-phase mains / commutating choke 4 % UK

## Advantages

- Compact design
- Extended service life for electrical loads
- Minimal thermal losses
- Damping of current peaks up to 60 %
- Reduction of the input current up to 20 %
- Low noise
- Production according to UL insulation system E251513 possible

## Description

- Nominal voltage:  $U \leq 250 \text{ V}$
- Short-circuit voltage:  $U_k 4 \% (230\text{VAC}/50\text{Hz}, I_{\text{Rated}})$
- Frequency: 50/60 Hz
- According to: EN 60289 / EN 61558
- Test voltage: L-PE 2500 V, DC 1min
- Insulation class: T40/F
- Protection class: IP 00
- Climate category: DIN IEC 60068-1
- Overload:  $1.5 \times I_{\text{Rated}}$  1 min/h
- Design: standing Mounting brackets

N CNW 901

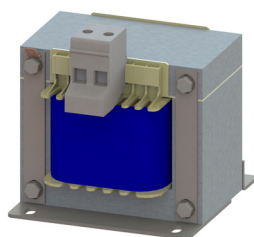

Design 1

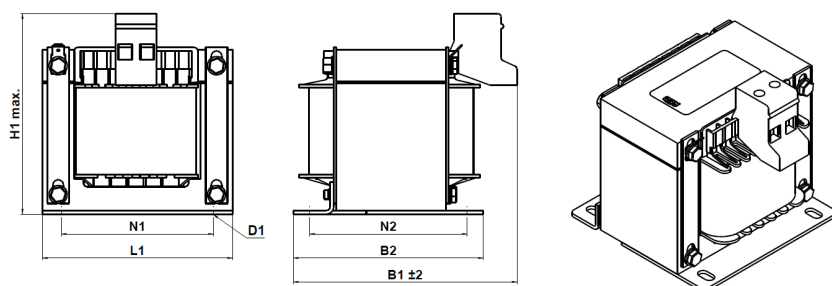

Design 2

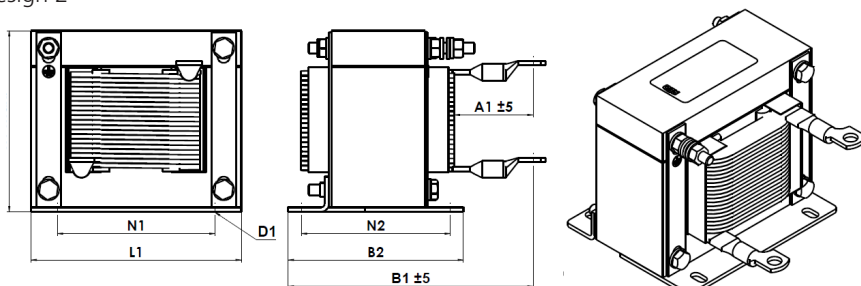

## Technical details

N CNW 901						
Type	Nominal voltage / nominal frequency [V]	Nominal current I [A]	Nominal inductance L [mH]	Losses P [W]	Weight [kg]	Weight Cu [kg]
N CNW 901 / 2	230 50 / 60 Hz	2	14,5	7	0,5	0,2
N CNW 901 / 4		4	7,3	11,3	0,5	0,2
N CNW 901 / 6		6	4,88	13,5	0,6	0,2
N CNW 901 / 8		8	3,6	17	0,7	0,2
N CNW 901 / 10		10	2,9	34	0,7	0,2
N CNW 901 / 16		16	1,8	25	1,2	0,4
N CNW 901 / 20		20	1,5	28	2,0	0,4
N CNW 901 / 25		25	1,1	32	2,0	0,4
N CNW 901 / 30		30	0,95	35	2,1	0,5
N CNW 901 / 35		35	0,84	42	2,9	0,6
N CNW 901 / 40		40	0,73	42	3,6	0,8
N CNW 901 / 45		45	0,65	44	3,6	0,9
N CNW 901 / 50		50	0,57	50	4,6	1
N CNW 901 / 63		63	0,5	61	5,2	1,3
N CNW 901 / 75		75	0,4	70	6,9	1,6
N CNW 901 / 100		100	0,29	86	8,0	2



Higher performance upon request

Typical applications: Drive systems for motor drives, mechanical engineering pump, conveyor technology, ventilation and air conditioning, robotics, automation technology, power supplies

## Dimensions in mm

N CNW 901											
Type	Length	Weight		Height	Mounting			Connections			Design
	L [mm]	B1 [mm]	B2 [mm]	H [mm]	N1 [mm]	N2 [mm]	D1 [mm x mm]	Clamps/ Cross section [mm <sup>2</sup> ]	PE	A1 [mm]	
N CNW 901/2	60	65	47	67	44	36	4 x 7	2,5	Flat plug 6.3x0.8		1
N CNW 901/4	60	65	47	67	44	36	4 x 7	2,5	Flat plug 6.3x0.8		1
N CNW 901/6	60	65	47	67	44	36	4 x 7	2,5	Flat plug 6.3x0.8		1
N CNW 901/8	60	79	59	67	44	45	4 x 7	2,5	Flat plug 6.3x0.8		1
N CNW 901/10	66	70	57	72	50	43	5 x 8	2,5	Flat plug 6.3x0.8		1
N CNW 901/16	78	75	60	80	57	48	5 x 8	2,5	Flat plug 6.3x0.8		1
N CNW 901/20	84	90	76	80	64	62	5 x 8	4	Flat plug 6.3x0.8		1
N CNW 901/25	84	90	76	80	64	62	5 x 8	4	Flat plug 6.3x0.8		1
N CNW 901/30	84	90	76	80	64	62	5 x 8	10	Flat plug 6.3x0.8		1
N CNW 901/35	96	105	88	105	84	72	6 x 11	10	Flat plug 6.3x0.8		1
N CNW 901/40	96	142	102	90	84	85	6 x 11	16 (M6)	M5	40	2
N CNW 901/45	96	142	102	90	84	85	6 x 11	16 (M6)	M5	40	2
N CNW 901/50	105	145	105	95	84	87	6 x 11	16 (M6)	M5	40	2
N CNW 901/63	120	140	100	108	90	85	6 x 11	25 (M6)	M6	45	2
N CNW 901/75	120	165	120	108	90	105	6 x 11	35 (M8)	M6	50	2
N CNW 901/100	135	155	115	120	105	100	6 x 11	35 (M8)	M6	50	2

## N CNW 903

Three-phase line choke 4 %  $U_k$

### Advantages

- Compact design
- Extended service life for electrical loads
- Minimal thermal losses
- Damping of current peaks up to 60 %
- Reduction of the input current up to 20 %
- Low noise
- Production according to UL insulation system E251513 possible

### Description

- Nominal voltage:  $U \leq 3 \times 500 \text{ V}$
- Short-circuit voltage:  $U_k$  4 % (400VAC/50Hz,  $I_{\text{Rated}}$ )
- Frequency: 50/60 Hz
- According to: EN 60289 / EN 61558
- Test voltage: L-L 2500 V, DC 1 min; L-PE 2500 V, DC 1 min
- Insulation class: T40/F
- Protection class: IP 00
- Climate category: DIN IEC 60068-1
- Overload:  $1.5 \times I_{\text{Rated}}$  1 min/h
- Design: Mounted on brackets

N CNW 903

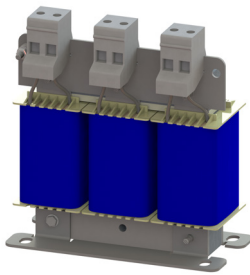

# Technical data

N CNW 903							
Type	Nominal voltage $U_N$ [V]	Nominal current $I_N$ [A]	Inductance L [mH]	Losses P [W]	Weight [kg]	Weight Cu [kg]	Weight Al [kg]
N CNW 903 / 3	500 50 / 60 Hz	3	9,800	16	1,0	0,2	-
N CNW 903 / 6		6	4,880	25	2,0	0,3	-
N CNW 903 / 8		8	3,680	35	2,0	0,3	-
N CNW 903 / 10		10	2,930	36	3,0	0,4	-
N CNW 903 / 12		12	2,450	38	3,0	0,5	-
N CNW 903 / 16		16	1,830	48	4,0	0,7	-
N CNW 903 / 25		25	1,170	63	5,2	0,8	-
N CNW 903 / 36		36	0,810	67	7,0	1,9	-
N CNW 903 / 50		50	0,590	100	10	1,8	-
N CNW 903 / 70		70	0,420	180	11	2,1	-
N CNW 903 / 90		90	0,330	144	17	2,5	-
N CNW 903 / 110		110	0,270	179	18	2,8	-
N CNW 903 / 125		125	0,235	220	17	2,6	-
N CNW 903 / 160		160	0,180	145	22	5,0	-
N CNW 903 / 200		200	0,147	187	26	1,3	3,8
N CNW 903 / 250		250	0,118	254	35	1,3	3,0
N CNW 903 / 300		300	0,098	250	37	1,3	4,7
N CNW 903 / 350		350	0,084	267	45	2,6	5,0
N CNW 903 / 400		400	0,074	365	52	2,6	5,2
N CNW 903 / 500		500	0,059	423	58	2,9	7,8
N CNW 903 / 600		600	0,049	450	71	5,0	6,9
N CNW 903 / 700		700	0,042	493	88	5,0	9,2
N CNW 903 / 800		800	0,037	545	96	5,1	8,3
N CNW 903 / 900		900	0,033	655	108	12,5	10,1
N CNW 903 / 1000	1000	0,029	775	108	12,5	10,1	
N CNW 903 / 1200	1200	0,024	1009	133	13,9	12,4	



Higher performance upon request

Typical applications: Drive systems for motor drives, mechanical engineering, elevators / escalators, pipes, conveyor technology, ventilation and air conditioning, robotics, automation technology, power supplies, wind turbines

## Dimensions in mm

N CNW 903														
Type	Length		Width		Height	Mounting			Clamps/ Cross section [mm <sup>2</sup> ]	Connection				Design
	L1 [mm]	L2 [mm]	B1 [mm]	B2 [mm]	H1 [mm]	N1 [mm]	N2 [mm]	D1 [mm x mm]		Angle [mm x mm]	A1 [mm]	D2 [mm]	PE	
N CNW 903 / 3	65	78	50	60	95	50	38	5 x 8	2,5	-	-	-	M4	1
N CNW 903 / 6	80	96	55	65	110	56	43	5 x 8	2,5	-	-	-	M4	1
N CNW 903 / 8	125	120	61	66	130	100	45	5 x 8	2,5	-	-	-	M4	1
N CNW 903 / 10	125	120	71	76	130	100	55	5 x 8	2,5	-	-	-	M4	1
N CNW 903 / 12	125	120	71	76	130	100	55	5 x 8	2,5	-	-	-	M4	1
N CNW 903 / 16	155	150	76	76	155	130	54	8 x 12	2,5	-	-	-	M4	1
N CNW 903 / 25	155	150	91	101	170	130	69	8 x 12	10	-	-	-	M4	1
N CNW 903 / 36	190	180	81	91	195	170	57	8 x 12	10	-	-	-	M6	1
N CNW 903 / 50	190	-	130	-	160	170	77	8 x 12	16 (M6)	-	45	-	M6	2
N CNW 903 / 70	230	-	136	-	200	176	73	9 x 13	16 (M8)	-	45	-	M8	2
N CNW 903 / 90	230	-	150	-	200	176	95	9 x 13	16 (M8)	-	45	-	M8	2
N CNW 903 / 110	240	-	150	-	210	185	97	10 x 18	16 (M8)	-	45	-	M8	2
N CNW 903 / 125	240	-	150	-	210	185	95	10 x 18	16 (M8)	-	45	-	M8	2
N CNW 903 / 160	240	-	175	-	210	185	103	10 x 18	35 (M10)	-	55	-	M8	2
N CNW 903 / 200	300	-	148	-	270	224	95	10 x 18	-	30 x 4	39	11	M12	3
N CNW 903 / 250	300	-	184	-	270	224	125	10 x 18	-	30 x 4	39	11	M12	3
N CNW 903 / 300	300	-	190	-	270	224	125	10 x 18	-	30 x 4	39	11	M12	3
N CNW 903 / 350	340	-	192	-	305	248	130	10 x 18	-	40 x 5	49	13	M12	3
N CNW 903 / 400	360	-	195	-	315	264	142	10 x 18	-	40 x 5	49	13	M12	3
N CNW 903 / 500	360	-	200	-	345	264	142	10 x 18	-	40 x 5	49	13	M12	3
N CNW 903 / 600	360	-	232	-	345	264	167	10 x 18	-	40 x 5	58	13	M12	3
N CNW 903 / 700	420	-	240	-	370	316	174	13 x 20	-	40 x 5	58	13	M12	3
N CNW 903 / 800	420	-	275	-	380	316	184	13 x 20	-	60 x 5	68	2 x 13	M12	3
N CNW 903 / 900	480	-	263	-	465	356	158	13 x 20	-	60 x 10	78	2 x 13	M12	3
N CNW 903 / 1000	480	-	263	-	465	356	158	13 x 20	-	60 x 10	78	2 x 13	M12	3
N CNW 903 / 1200	480	-	265	-	500	356	168	13 x 20	-	60 x 10	78	2 x 13	M12	3

N CNW 903 / 3 - N CNW 903 / 160 is also available on request with cable lug or cables.



Design 1

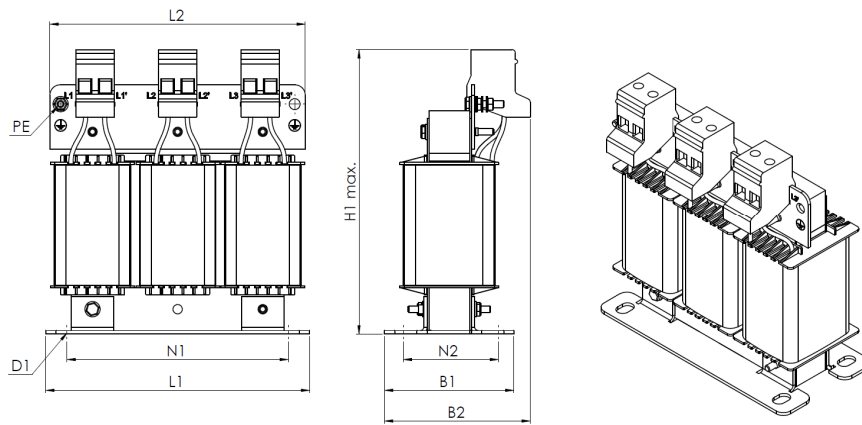

Design 2

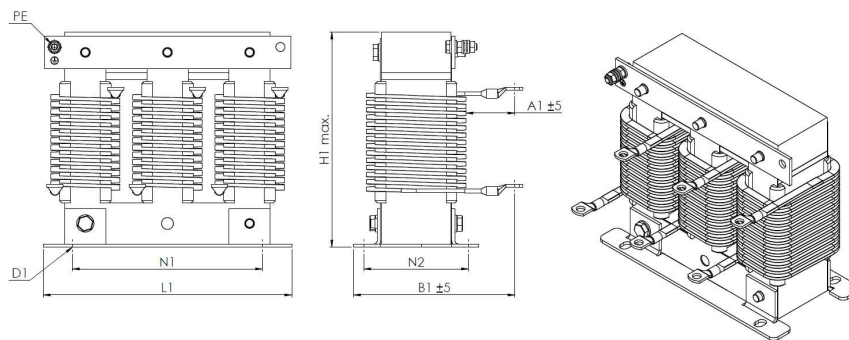

Design 3

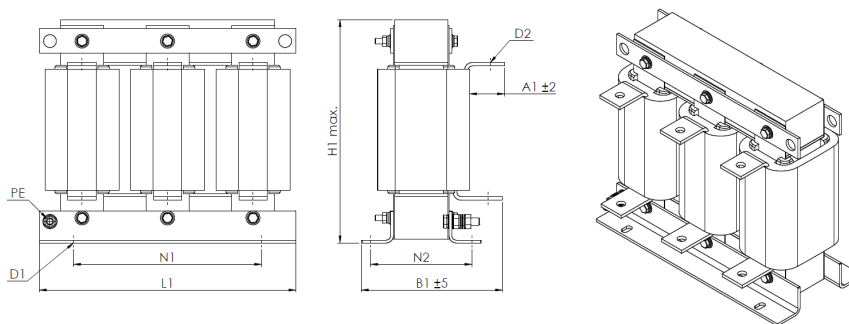

## N CNW 905

Three-phase line choke  $2 \% U_k$

### Advantages

- Compact design
- Extended service life for electrical loads
- Minimal thermal losses
- Damping of current peaks up to 30 %
- Reduction of the input current up to 15 %
- Low noise
- Production according to UL insulation system E251513 possible

### Description

- Nominal voltage:  $U \leq 3 \times 500 \text{ V}$
- Short-circuit voltage:  $U_k 2 \% (400\text{VAC}/50\text{Hz}, I_{\text{Rated}})$
- Frequency 50/60 Hz
- According to EN 60289 / EN 61558
- Test voltage L-L 2500 V, DC 1 min; L-PE 2500 V, DC 1 min
- Insulation class T40/F
- Protection class: IP 00
- Climate category: DIN IEC 60068-1
- Overload  $1.5 \times I_{\text{Rated}}$  1 min/h
- Design: Mounted on brackets

N CNW 905

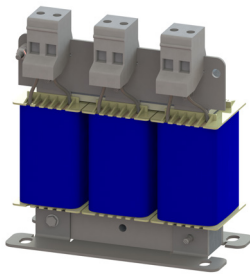

## Technical details

N CNW 905							
Type	Nominal voltage $U_N$ [V]	Nominal current $I_N$ [A]	Inductance L [mH]	Losses P [W]	Weight [kg]	Weight Cu [kg]	Weight Al [kg]
N CNW 905 / 3	500 50 / 60 Hz	3	4,900	8	1	0,1	-
N CNW 905 / 6		6	2,440	15	1	0,2	-
N CNW 905 / 8		8	1,830	21	1	0,2	-
N CNW 905 / 10		10	1,460	20	2	0,2	-
N CNW 905 / 12		12	1,220	22	2	0,3	-
N CNW 905 / 16		16	0,910	26	3	0,5	-
N CNW 905 / 25		25	0,580	37	3	0,5	-
N CNW 905 / 36		36	0,400	43	4	0,7	-
N CNW 905 / 50		50	0,290	61	5	0,6	-
N CNW 905 / 70		70	0,200	100	10	0,9	-
N CNW 905 / 90		90	0,160	104	11	1,2	-
N CNW 905 / 110		110	0,130	133	11	1,5	-
N CNW 905 / 125		125	0,120	112	11	0,6	0,8
N CNW 905 / 160		160	0,090	101	16	0,8	1,1
N CNW 905 / 200		200	0,073	131	20	1,1	1,4
N CNW 905 / 250		250	0,059	180	21	1,0	1,2
N CNW 905 / 300		300	0,050	161	24	1,3	2,7
N CNW 905 / 350		350	0,042	201	25	2,2	2,7
N CNW 905 / 400		400	0,036	207	37	2,6	3,1
N CNW 905 / 500		500	0,030	241	38	2,6	4,1
N CNW 905 / 600		600	0,024	314	43	4,4	3,5
N CNW 905 / 700		700	0,021	365	57	5,0	4,4
N CNW 905 / 800		800	0,018	430	60	5,0	5,1
N CNW 905 / 900		900	0,016	499	66	10,8	5,5
N CNW 905 / 1000	1000	0,015	657	73	12,5	5,1	
N CNW 905 / 1200	1200	0,012	791	79	13,8	5,9	



Higher performance on request

Typical applications: Drive systems for motor drives, mechanical engineering, elevators / escalators, pipes, conveyor technology, ventilation and air conditioning, robotics, automation technology, power supplies, wind turbines

## Dimensions in mm

N CNW 905														
Type	Length		Width		Height	Mounting			Clamps/ Cross section [mm <sup>2</sup> ]	Connection				Design
	L1 [mm]	L2 [mm]	B1 [mm]	B2 [mm]	H1 [mm]	N1 [mm]	N2 [mm]	D1 [mm x mm]		Angle [mm x mm]	A1 [mm]	D2 [mm]	PE Ø [mm]	
N CNW 905 / 3	65	78	50	60	95	50	38	5 x 8	2.5	-	-	-	M4	1
N CNW 905 / 6	65	78	50	60	95	50	38	5 x 8	2.5	-	-	-	M4	1
N CNW 905 / 8	80	96	65	65	110	56	34	5 x 8	2.5	-	-	-	M4	1
N CNW 905 / 10	80	96	65	65	110	56	43	5 x 8	2.5	-	-	-	M4	1
N CNW 905 / 12	80	96	65	65	110	56	43	5 x 8	2.5	-	-	-	M4	1
N CNW 905 / 16	125	120	61	66	130	100	45	5 x 8	2.5	-	-	-	M4	1
N CNW 905 / 25	125	120	71	86	145	100	55	5 x 8	10	-	-	-	M4	1
N CNW 905 / 36	155	150	76	86	170	130	54	8 x 12	10	-	-	-	M6	1
N CNW 905 / 50	155	150	91	101	170	130	69	8 x 12	10	-	-	-	M6	1
N CNW 905 / 70	230	-	125	-	200	176	73	9 x 13	16 (M8)	-	45	-	M8	2
N CNW 905 / 90	230	-	125	-	200	176	73	9 x 13	16 (M8)	-	45	-	M8	2
N CNW 905 / 110	230	-	125	-	200	176	73	9 x 13	16 (M8)	-	45	-	M8	2
N CNW 905 / 125	230	-	112	-	200	176	71	9 x 13	-	25 x 3	33	9	M8	3
N CNW 905 / 160	230	-	140	-	200	176	95	9 x 13	-	30 x 3	38	11	M8	3
N CNW 905 / 200	240	-	160	-	210	185	107	10 x 18	-	30 x 4	39	11	M8	3
N CNW 905 / 250	240	-	165	-	210	185	112	10 x 18	-	30 x 4	39	11	M8	3
N CNW 905 / 300	300	-	151	-	270	224	95	10 x 18	-	30 x 4	39	11	M12	4
N CNW 905 / 350	300	-	162	-	270	224	95	10 x 18	-	40 x 5	49	13	M12	4
N CNW 905 / 400	340	-	171	-	305	248	115	10 x 18	-	40 x 5	48	13	M12	4
N CNW 905 / 500	340	-	171	-	305	248	115	10 x 18	-	40 x 5	48	13	M12	4
N CNW 905 / 600	360	-	192	-	315	264	127	10 x 18	-	40 x 8	58	13	M12	4
N CNW 905 / 700	420	-	197	-	370	316	134	13 x 20	-	40 x 8	58	13	M12	4
N CNW 905 / 800	420	-	228	-	390	316	134	13 x 20	-	60 x 5	68	2 x 13	M12	4
N CNW 905 / 900	420	-	238	-	390	316	134	13 x 20	-	60 x 10	78	2 x 13	M12	4
N CNW 905 / 1000	420	-	241	-	440	316	134	13 x 20	-	60 x 10	78	2 x 13	M12	4
N CNW 905 / 1200	420	-	241	-	475	316	134	13 x 20	-	60 x 10	78	2 x 13	M12	4

\*N CNW 905 / 3 - N CNW 905 / 160 is also available on request with cable lug or cables.

Design 1

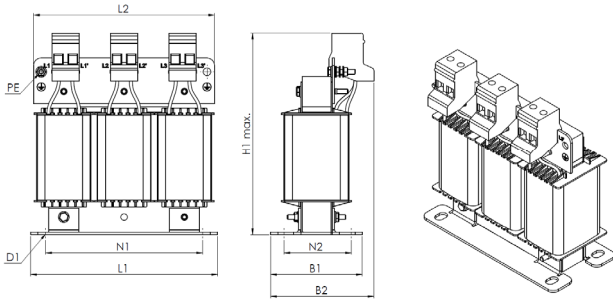

Design 2

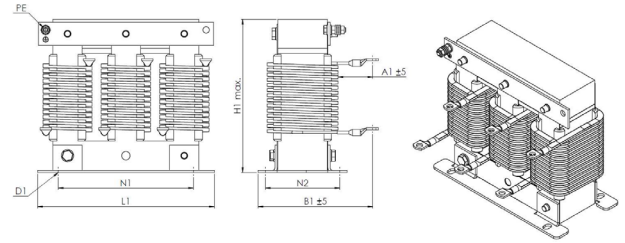

Design 3

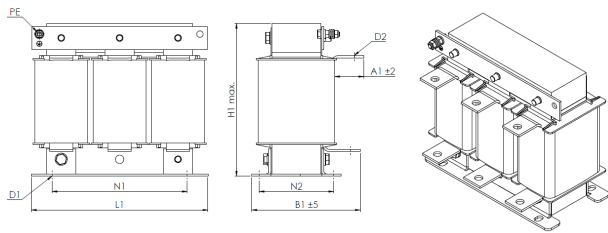

Design 4

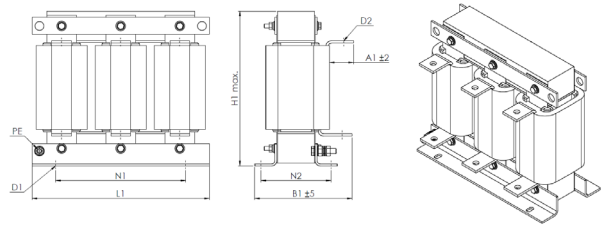

## N CNW 891

### Advantages

- Reduction of harmonic currents
- Damping of current peaks up to 70 %
- Compact design
- Advantages compared to the line choke:
  - Smaller size
  - Reduced material costs / price
  - Lower power dissipation
- Production according to UL insulation system E251513 possible

### Description

- Nominal voltage:  $U \leq 600$  V
- According to: EN 60289 / EN 61558
- Test voltage: L-PE 4000 V, AC/50 Hz, 60 s
- Insulation class: T40/F
- Protection class: IP 00
- Climate category: DIN IEC 60068-1
- Overload:  $1.5 \times I_{\text{Rated}}$  1 min/h
- Design: Mounted on brackets

N CNW 891

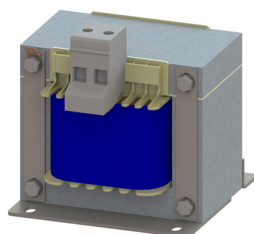

### Technical details

N CNW 891						
Type	Nominal voltage U [V]	Nominal current [A]	Inductance [mH]	Power dissipation [W]	Weight [kg]	Weight Cu [kg]
N CNW 891 / 8	600 50 / 60 Hz	8	9,4	14	1,4	0,3
N CNW 891 / 11		11	6,2	15	2	0,3
N CNW 891 / 15		15	4,8	20	2,8	0,6
N CNW 891 / 20	800 50 / 60 Hz	20	3,3	19	3,6	0,6
N CNW 891 / 28		28	2,4	22	3,6	0,8
N CNW 891 / 34		34	2,0	29	4,5	0,8
N CNW 891 / 40		40	1,6	31	7	1
N CNW 891 / 55		55	1,2	43	8	1,2
N CNW 891 / 70		70	0,98	49	10,5	1,4
N CNW 891 / 85		85	0,81	60	13,6	1,8
N CNW 891 / 100		100	0,67	70	14	2,5



Typical applications: Drive systems for motor drives, mechanical engineering, elevators / escalators, pipes, conveyor technology, ventilation and air conditioning, robotics, automation technology, power supplies, wind turbines

# Dimensions in mm

N CNW 905												
Type	Length	Width		Height	Mounting			Connection			Design	
	L1 [mm]	B1 [mm]	B2 [mm]	H [mm]	N1 [mm]	N2 [mm]	D1 [mm x mm]	Clamps/ Cross section [mm <sup>2</sup> ]	PE	A1 [mm]		
N CNW 891 / 8	84	76	62	80	64	48	5 x 8	2,5	Flat plug 6,3 x 0,8	-	1	
N CNW 891 / 11	84	90	76	80	64	62	5 x 8	2,5	Flat plug 6,3 x 0,8	-	1	
N CNW 891 / 15	96	95	88	85	84	72	6 x 11	2,5	Flat plug 6,3 x 0,8	-	1	
N CNW 891 / 20	96	138	102	85	84	85	6 x 11	10 (M5)	M5	40	2	
N CNW 891 / 28	96	138	102	85	84	85	6 x 11	16 (M5)	M5	40	2	
N CNW 891 / 34	105	138	105	95	84	87	6 x 11	16 (M5)	M5	40	2	
N CNW 891 / 40	120	155	120	105	90	105	6 x 11	16 (M6)	M6	45	2	
N CNW 891 / 55	150	138,5	107,5	135	122	87,5	7 x 13	16 (M6)	M6	45	2	
N CNW 891 / 70	150	159	124,5	135	122	104,5	7 x 13	25 (M8)	M6	45	2	
N CNW 891 / 85	150	185,5	150,5	135	122	130,5	7 x 13	25 (M8)	M6	45	2	
N CNW 891 / 100	174	162,5	121	150	135	101	7 x 13	35 (M8)	M8	50	2	

Design 1

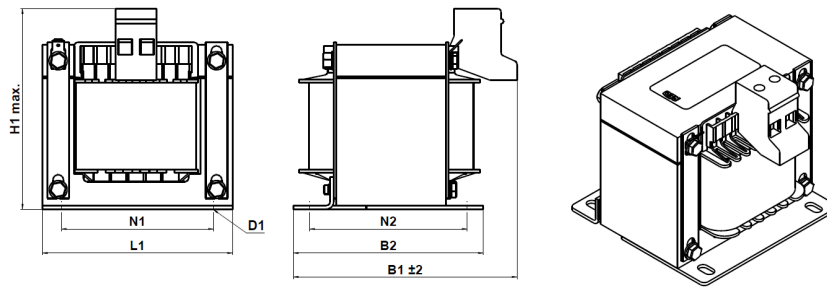

Design 2

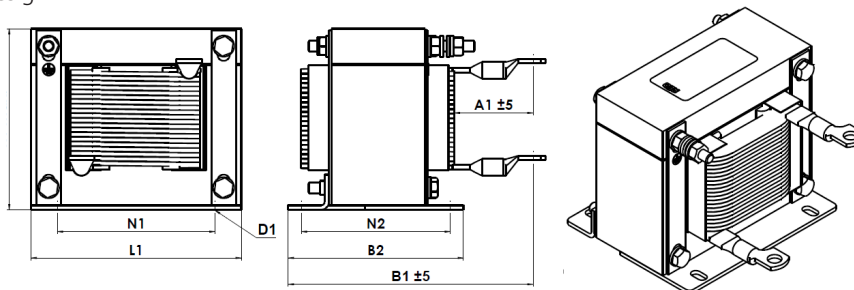

# N CNW 892

DC-link chokes (2 lines)

## Advantages

- Reduction of harmonic waves
- Damping of current peaks up to 70 %
- Compact design
- Advantages compared to the line choke:
  - Smaller size
  - Reduced material costs / price
  - Lower power dissipation
- Production according to UL insulation system E251513 possible

## Description

- Nominal voltage:  $U \leq 800$  V
- According to: EN 60289 / EN 61558
- Test voltage: L-PE 4000 V, AC/50 Hz, 60s
- Insulation class: T40/F
- Protection class: IP 00
- Climate category: DIN IEC 60068-1
- Overload:  $1.5 \times I_{Rated}$  1 min/h
- Design: Mounted on brackets

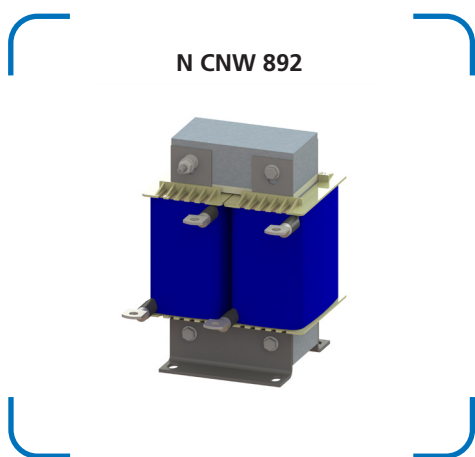

Design 1

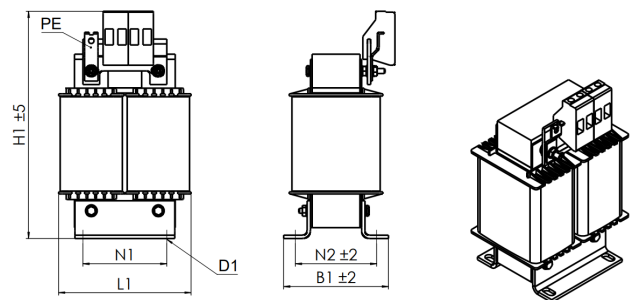

Design 2

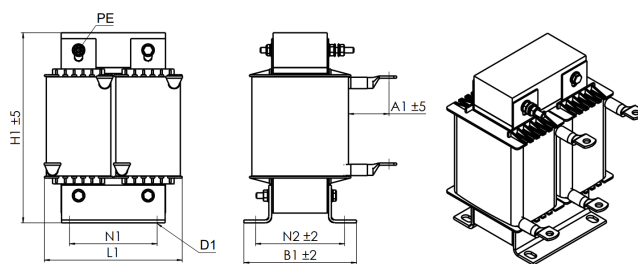

Design 3

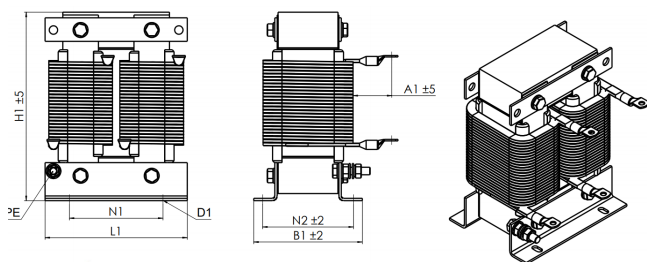



## Technical details

N CNW 892						
Type	Nominal voltage U [V]	Nominal current I [A]	Inductance L [mH]	Losses P [W]	Weight [kg]	Weight Cu [kg]
N CNW 892 / 8	600 50 / 60 Hz	8	9,4	30	1,4	0,6
N CNW 892 / 11		11	6,2	30	2,0	0,6
N CNW 892 / 15		15	4,8	40	2,4	0,8
N CNW 892 / 20	800 50 / 60 Hz	20	3,3	30	3,0	1,2
N CNW 892 / 28		28	2,4	40	3,8	1,1
N CNW 892 / 34		34	2,0	40	4,0	1,3
N CNW 892 / 40		40	1,6	70	5,0	1,2
N CNW 892 / 55		55	1,2	80	6,0	1,4
N CNW 892 / 70		70	0,98	80	8,0	2,3
N CNW 892 / 85		85	0,81	90	11,0	2,0
N CNW 892 / 100		100	0,67	120	13,0	1,8



Typical applications: Drive systems for motor drives, mechanical engineering, elevators / escalators, pipes, conveyor technology, ventilation and air conditioning, robotics, automation technology, power supplies, wind turbines

## Dimensions in mm

N CNW 892										
Type	Dimensions			Mounting			Connection			
	L [mm]	B [mm]	H [mm]	N1 [mm]	N2 [mm]	D1 [mm]	Clamps/ Cross section [mm <sup>2</sup> ]	PE	A1 [mm]	Design
N CNW 892 / 8	80	53	135	50	39	4,8 x 9	4,0	M4	-	1
N CNW 892 / 11	80	63	135	50	49	4,8 x 9	4,0	M4	-	1
N CNW 892 / 15	100	66	155	63	49	6 x 10	4,0	M4	-	1
N CNW 892 / 20	100	66	140	63	49	6 x 10	10 (M4)	M4	35	2
N CNW 892 / 28	100	81	140	63	64	6 x 10	10 (M5)	M4	35	2
N CNW 892 / 34	100	81	140	63	64	6 x 10	16 (M5)	M4	35	2
N CNW 892 / 40	120	87,5	165	76	68,5	7 x 13	10 (M6)	M6	40	3
N CNW 892 / 55	120	97,5	165	76	78,5	7 x 13	16 (M6)	M6	40	3
N CNW 892 / 70	152	92	205	100	73	7 x 13	25 (M8)	M8	45	3
N CNW 892 / 85	152	112	205	100	93	7 x 13	25 (M8)	M8	45	3
N CNW 892 / 100	160	127	215	100	103	7 x 13	25 (M8)	M8	45	3

# N CNW 806

Three-phase-dv/dt filter

## Advantages

- Protection for electrical loads
- Limitation of voltage rise to  $< 500 \text{ V}/\mu\text{s}$
- Extended service life for electrical loads
- Low leakage currents at the motor
- Low total loss
- Easy assembly
- Compact design
- Production according to UL insulation system E251513 possible

## Description

- Nominal voltage:  $U \leq 3 \times 500 \text{ V}$
- Reduction of the voltage rise  $DV/DT$  to  $< 500 \text{ V}/\mu\text{s}$
- Rotating field frequency: 0 - 60 Hz
- Clock frequency of the inverter: up to 150 A  $> 4 \text{ kHz}$ , from 150 A  $> 1.5 \text{ kHz}$
- According to: EN 60289 / EN 61558
- Test voltage: L-L 2500 V, AC/50 Hz 60s; L-PE 2500 V, AC/50 Hz 60s
- Insulation class: T40/F
- Protection class: IP 00
- Climate category: DIN IEC 60068-1
- Overload:  $1.5 \times I_{\text{Rated}}$  1 min/h
- Ambient temperature 40 °C)
- Design: Mounted on brackets

N CNW 806

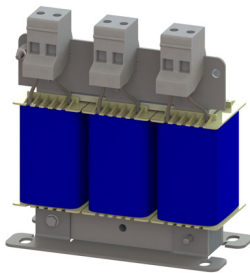

## Technical details

N CNW 806												
Type	Nominal voltage U [V]	Nominal current I [A]	Inductance L [mH]	Resistance R [mΩ]	Losses P [W]	U <sub>κ</sub> at 400 V, 50 Hz [%]	U <sub>κ</sub> at 230 V, 50 Hz [%]	U <sub>κ</sub> at 480 V, 60 Hz [%]	U <sub>κ</sub> at 500 V, 50 Hz [%]	Weight [kg]	Weight Cu [kg]	Weight Al [kg]
N CNW 806 / 4	500 50 / 60 Hz	4	1,500	92,7	10	0,8	1,4	0,8	0,7	1,0	0,2	
N CNW 806 / 10		10	0,600	26,4	20		1,4	0,8	0,7	2,0	0,2	-
N CNW 806 / 18		18	0,330	12,0	20		1,4	0,8	0,6	2,0	0,3	-
N CNW 806 / 24		24	0,245	9,1	30		1,4	0,8	0,6	2,5	0,3	-
N CNW 806 / 37		37	0,160	4,8	30		1,4	0,8	0,6	3,0	0,6	-
N CNW 806 / 48		48	0,123	2,7	40		1,4	0,8	0,6	3,0	0,5	-
N CNW 806 / 65		65	0,090	2,0	50		1,4	0,8	0,6	4,0	0,6	-
N CNW 806 / 90		90	0,065	1,5	60		1,4	0,8	0,6	5,0	0,8	-
N CNW 806 / 120		120	0,050	1,1	80		1,4	0,8	0,7	7,0	1,5	-
N CNW 806 / 150		150	0,039	0,5	60		1,4	0,8	0,6	8,0	1,7	-
N CNW 806 / 180		180	0,033	0,5	80		1,4	0,8	0,6	9,0	1,4	-
N CNW 806 / 200		200	0,029	0,5	100		1,4	0,8	0,6	9,0	1,5	-
N CNW 806 / 250		250	0,024	0,22	120		1,4	0,8	0,7	15,0	1,1	1,50
N CNW 806 / 300		300	0,020	0,15	140		1,4	0,8	0,7	16,0	1,2	2,55
N CNW 806 / 350		350	0,017	0,13	140		1,4	0,8	0,6	21,0	6,5	-
N CNW 806 / 400		400	0,015	0,10	150		1,4	0,8	0,7	24,0	2,2	2,25
N CNW 806 / 500		500	0,012	0,10	200		1,4	0,8	0,7	27,0	2,6	3,30
N CNW 806 / 600		600	0,010	0,08	250		1,4	0,8	0,7	32,0	4,4	2,55
N CNW 806 / 700		700	0,008	0,07	260		1,3	0,8	0,6	35,0	4,9	3,00
N CNW 806 / 800		800	0,007	0,06	280		1,3	0,8	0,6	36,0	5,2	3,90
N CNW 806 / 900	900	0,0065	0,05	290	1,4	0,8	0,6	55,0	10,8	5,55		
N CNW 806 / 1000	1000	0,006	0,05	360	1,4	0,8	0,7	56,0	10,8	5,85		
N CNW 806 / 1200	1200	0,005	0,05	480	1,4	0,8	0,7	56,0	10,8	6,00		



Typical applications: Drive systems for motor drives, mechanical engineering, elevators / escalators, pipes, conveyor technology, ventilation and air conditioning, robotics, automation technology, power supplies, wind turbines

## Dimensions in mm

N CNW 806														
Type	Length		Width		Height	Mounting			Clamps/ Cross section [mm <sup>2</sup> ]	Connection				Design
	L1 [mm]	L2 [mm]	B1 [mm]	B2 [mm]	H1 [mm]	N1 [mm]	N2 [mm]	D1 [mm x mm]		Angle [mm x mm]	A1 [mm]	D2 [mm]	PE Ø [mm]	
N CNW 806 / 4	65	78	50	60	95	50	38	5 x 8	2,5	-	-	-	M4	1
N CNW 806 / 10	80	96	45	55	110	65	34	5 x 8	2,5	-	-	-	M4	1
N CNW 806 / 18	80	96	5	65	110	65	43	5 x 8	2,5	-	-	-	M4	1
N CNW 806 / 24	125	120	61	76	145	100	45	5 x 8	10	-	-	-	M4	1
N CNW 806 / 37	125	-	90	-	105	100	45	5 x 8	10 (M6)	-	40	-	M6	2
N CNW 806 / 48	125	-	100	-	105	100	55	5 x 8	10 (M6)	-	40	-	M6	2
N CNW 806 / 65	155	-	110	-	130	130	54	8 x 12	16 (M8)	-	40	-	M6	2
N CNW 806 / 90	155	-	120	-	130	130	69	8 x 12	16 (M8)	-	40	-	M6	2
N CNW 806 / 120	190	-	115	-	160	170	57	8 x 12	25 (M8)	-	45	-	M8	2
N CNW 806 / 150	190	-	130	-	160	170	67	8 x 12	25 (M10)	-	45	-	M10	2
N CNW 806 / 180	190	-	140	-	160	170	77	8 x 12	25 (M10)	-	45	-	M10	2
N CNW 806 / 200	190	-	140	-	160	170	77	8 x 12	25 (M10)	-	45	-	M10	2
N CNW 806 / 250	240	-	145	-	210	185	84	10 x 18	-	30 x 4	45	11	M12	3
N CNW 806 / 300	240	-	140	-	210	185	84	10 x 18	-	30 x 4	45	11	M12	3
N CNW 806 / 350	240	-	155	-	210	185	94	10 x 18	-	40 x 5	50	13	M12	3
N CNW 806 / 400	300	-	150	-	265	224	95	10 x 18	-	40 x 5	50	13	M12	3
N CNW 806 / 500	300	-	160	-	295	224	95	10 x 18	-	40 x 5	50	13	M12	3
N CNW 806 / 600	300	-	177	-	295	224	105	10 x 18	-	40 x 8	60	13	M12	3
N CNW 806 / 700	300	-	177	-	325	224	105	10 x 18	-	40 x 8	60	13	M12	3
N CNW 806 / 800	300	-	195	-	325	224	105	10 x 18	-	60 x 5	70	2 x 13	M12	3
N CNW 806 / 900	420	-	207	-	390	316	124	10 x 18	-	60 x 10	80	2 x 13	M12	3
N CNW 806 / 1000	420	-	217	-	390	316	124	13 x 20	-	60 x 10	80	2 x 13	M12	3
N CNW 806 / 1200	420	-	217	-	390	316	124	13 x 20	-	60 x 10	80	2 x 13	M12	3

Design 1

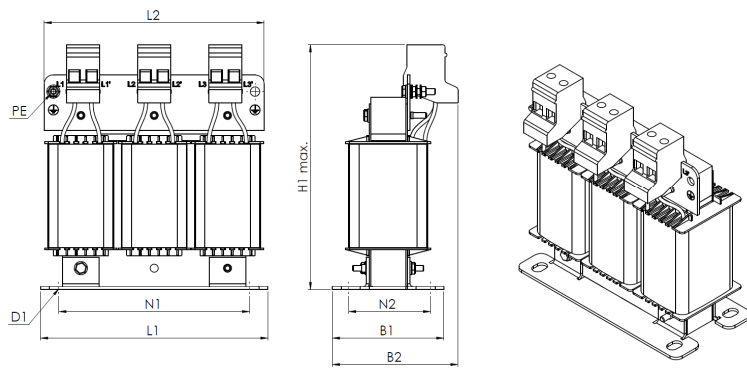

Design 2

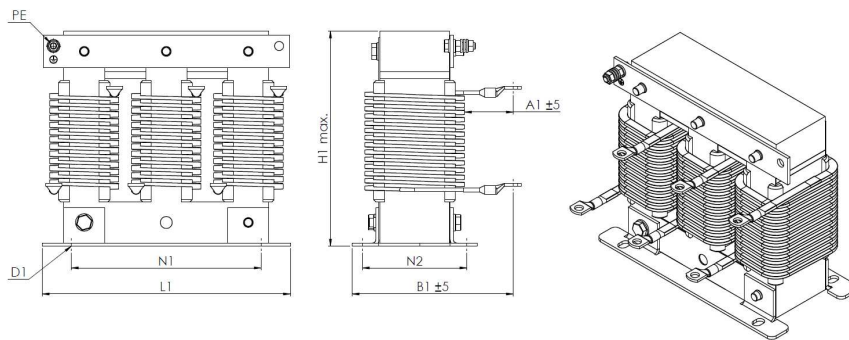

Design 3

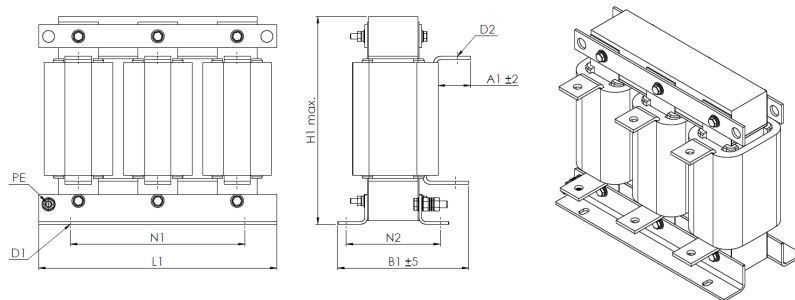

# CNW M 833

Fully-cast three-phase DV/DT filter

## Advantages

- Use in harsh environments
- Protection class: IP 00 - IP 66
- Optimum mechanical protection of the choke
- Protection for electrical loads
- Limitation of voltage rise to < 500 V/μs
- Extended service life for electrical loads
- Low leakage currents at the motor
- Low total loss
- Very low noise
- Easy assembly
- Production according to UL insulation system E251513 possible

## Description

- Nominal voltage:  $U \leq 3 \times 400 \text{ V}$
- Reduction of the voltage rise DV/DT to < 500 V/μs
- Max length of supply cable to motor: 200 m
- Rotating field frequency: 10 - 60 Hz
- Short-circuit voltage UK at 400 V: 0.8 %
- Clock frequency of the inverter: 4 kHz > ft < 8 kHz
- According to: EN 60289 / EN 61558
- Test voltage: L-L 2500 V, AC/50 Hz 60 s; L-PE 2500 V, AC/50Hz 60 s
- Insulation class: T40/F
- Protection class: IP 00 - IP 66
- Climate category: DIN IEC 60068-1
- Overload:  $1.5 \times I_{\text{rated}}$  1 min/h
- Ambient temperature 40 °C)
- Design: Mounted on brackets



## Technical details

CNW M 833								
Type	Protection class	Nominal voltage [V]	Nominal current [A]	Inductance [mH]	Capacitance [pF]	Weight [kg]	Clamp [mm²]	Cable screw connection
CNW M 833 / 8	IP 66	3 x 400 ≤ 60 Hz	8	2	330	3,3	2,5	M20x1,5
CNW M 833 / 16	IP 66		16	0,9	330	4,5	6	M25x1,5
CNW M 833 / 36	IP 65		36	0,42	1500	9	16	M32x1,5
CNW M 833 / 60	IP 65		60	0,27	2200	25	35	M40x1,5
CNW M 833 / 90	IP 65		90	0,17	4700	27	35	M40x1,5
CNW M 833 / 180	IP 65		175	0,09	10000	40	95	M63x1,5



Typical applications: Drive systems for motor drives, mechanical engineering, elevators / escalators, pipes, conveyor technology, ventilation and air conditioning, robotics, automation technology, power supplies, wind turbines

# Dimensions in mm

CNW M 833															
Type	Measurements														Design
	L1 [mm]	L2 [mm]	L3 [mm]	B1 [mm]	B2 [mm]	B3 [mm]	B4 [mm]	B5 [mm]	H1 [mm]	H2 [mm]	H3 [mm]	N1 [mm]	N2 [mm]	D [mm]	
CNW M 833 / 8	170	140	150	80	80	55	20,5	5,5	170	57	75	135	65	5,5x7	1
CNW M 833 / 16	180	140	170	85	80	65	10,5	5,5	170	57	75	155	70	5,5x7	1
CNW M 833 / 36	245	175	175	115	120	80	20	20	250	140	110	155	95	5,5x15	1
CNW M 833 / 60	315	249	255	180	175	120	30	27	323	218	105	185	150	9x13	1
CNW M 833 / 90	315	250	255	180	175	120	30	25	325	218	105	185	150	9x13	1
CNW M 833 / 180	355	270	-	127	200	160	105	8	350	220	130	185	105	10x18	2

Design 1

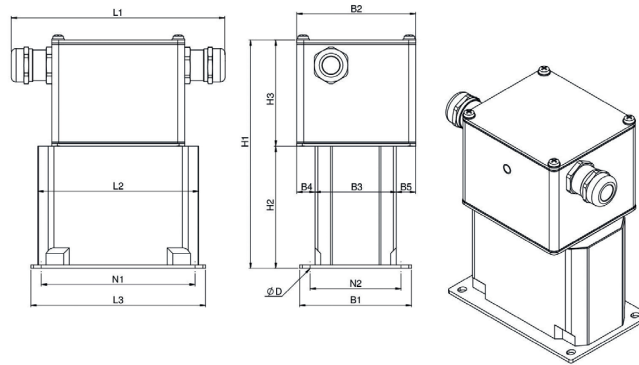

Design 2

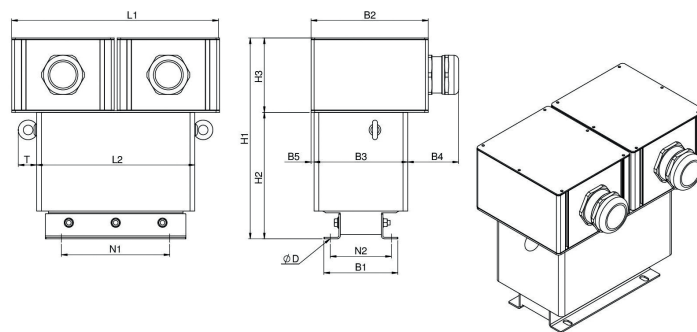

# N CNW 854

Three-phase motor choke

## Advantages

- Protection for electrical loads
- Limitation of voltage rise to  $< 200 \text{ V}/\mu\text{s}$
- Extended service life for electrical loads
- Reduction of audible motor noise
- Low leakage currents at the motor
- Longer motor cables possible
- Easy assembly
- Compact design
- Production according to UL insulation system E251513 possible

## Description

- Nominal voltage:  $U \leq 3 \times 500 \text{ V}$
- Reduction of the voltage rise  $DV/DT$  to  $< 200 \text{ V}/\mu\text{s}$
- Rotating field frequency:  $0 - 60 \text{ Hz}$
- Clock frequency of the inverter: up to  $150 \text{ A} > 4 \text{ kHz}$ , from  $150 \text{ A} > 1.5 \text{ kHz}$
- According to: EN 60289 / EN 61558
- Test voltage: L-L 2500 V, AC/50 Hz 60 s; L-PE 2500 V, AC/50 Hz 60 s
- Insulation class: T40/F
- Protection class: IP 00
- Climate category: DIN IEC 60068-1
- Overload:  $1.5 \times I_{\text{Rated}} 1 \text{ min/h}$
- Ambient temperature  $40 \text{ }^\circ\text{C}$
- Design: Mounted on brackets

N CNW 854

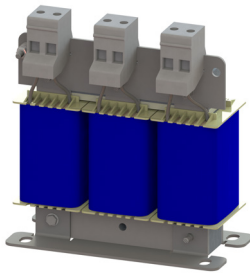



## Technical details

N CNW 854							
Type	Nominal voltage U [V]	Nominal current I [A]	Inductance L [mH]	Losses P [W]	Weight [kg]	Weight Cu [kg]	Weight Al [kg]
N CNW 854 / 2	500 50 / 60 Hz	2	7,00	21	1,0	0,3	-
N CNW 854 / 4		4	3,60	26	1,1	0,5	-
N CNW 854 / 8		8	2,00	35	2,0	0,5	-
N CNW 854 / 10		10	1,70	44	2,2	0,9	-
N CNW 854 / 12		12	1,20	52	2,7	0,8	-
N CNW 854 / 16		16	0,90	54	2,8	0,9	-
N CNW 854 / 24		24	0,70	55	4,4	1,9	-
N CNW 854 / 30		30	0,50	40	4,5	0,9	-
N CNW 854 / 37		37	0,42	40	6,0	1,4	-
N CNW 854 / 48		48	0,32	60	7,0	1,9	-
N CNW 854 / 60		60	0,28	80	7,0	2,0	-
N CNW 854 / 75		75	0,22	100	8,0	1,4	-
N CNW 854 / 90		90	0,17	80	10,0	1,9	-
N CNW 854 / 115		115	0,14	150	14,0	1,6	-
N CNW 854 / 150		150	0,11	170	16,0	3,1	-
N CNW 854 / 180		180	0,09	160	18,0	3,2	-
N CNW 854 / 200		200	0,08	170	23,0	2,8	-
N CNW 854 / 250		250	0,065	240	24,0	3,8	-
N CNW 854 / 300		300	0,053	380	44,0	1,5	2,7
N CNW 854 / 350		350	0,046	330	55,0	2,6	4,6
N CNW 854 / 400		400	0,041	380	58,0	2,6	4,9
N CNW 854 / 500		500	0,032	520	63,0	2,6	5,2
N CNW 854 / 600		600	0,028	650	65,0	5,0	5,9
N CNW 854 / 700		700	0,024	820	86,0	5,0	5,7
N CNW 854 / 800	800	0,021	710	108,0	6,6	9,0	
N CNW 854 / 900	900	0,018	800	114,0	13,8	7,6	
N CNW 854 / 1000	1000	0,016	900	114,0	13,8	7,6	
N CNW 854 / 1200	1200	0,013	1170	122,0	13,8	8,0	



Typical applications: Drive systems for motor drives, mechanical engineering, elevators / escalators, pipes, conveyor technology, ventilation and air conditioning, robotics, automation technology, power supplies, wind turbines

## Dimensions in mm

N CNW 854														
Type	Length		Width		Height	Mounting			Clamps/ Cross section [mm <sup>2</sup> ]	Connection				Design
	L1 [mm]	L2 [mm]	B1 [mm]	B2 [mm]	H1 [mm]	N1 [mm]	N2 [mm]	D1 [mm x mm]		Angle [mm x mm]	A1 [mm]	D2 [mm]	PE Ø [mm]	
N CNW 854 / 2	80	96	45	55	110	56	34	5 x 8	2.5	-	-	-	M4	1
N CNW 854 / 4	80	96	45	55	110	56	34	5 x 8	2.5	-	-	-	M4	1
N CNW 854 / 8	80	96	55	65	110	56	43	5 x 8	2.5	-	-	-	M4	1
N CNW 854 / 10	125	120	61	66	130	100	45	5 x 8	2.5	-	-	-	M4	1
N CNW 854 / 12	125	120	71	67	130	100	55	5 x 8	2.5	-	-	-	M4	1
N CNW 854 / 16	125	120	71	67	130	100	55	5 x 8	2.5	-	-	-	M4	1
N CNW 854 / 24	155	150	76	86	170	130	54	8 x 12	10	-	-	-	M4	1
N CNW 854 / 30	155	-	110	-	130	130	54	8 x 12	16 (M6)	-	40	-	M6	2
N CNW 854 / 37	155	-	125	-	130	130	69	8 x 12	16 (M6)	-	40	-	M6	2
N CNW 854 / 48	190	-	115	-	160	170	57	8 x 12	16 (M8)	-	40	-	M8	2
N CNW 854 / 60	190	-	115	-	160	170	57	8 x 12	16 (M8)	-	40	-	M8	2
N CNW 854 / 75	190	-	125	-	160	170	67	8 x 12	16 (M8)	-	40	-	M8	2
N CNW 854 / 90	190	-	135	-	160	170	77	8 x 12	16 (M8)	-	40	-	M8	2
N CNW 854 / 115	240	-	145	-	210	185	84	10 x 18	25 (M10)	-	55	-	M10	2
N CNW 854 / 150	240	-	145	-	210	185	84	10 x 18	25 (M10)	-	55	-	M10	2
N CNW 854 / 180	240	-	155	-	210	185	94	10 x 18	25 (M10)	-	55	-	M10	2
N CNW 854 / 200	300	-	160	-	270	224	95	10 x 18	25 (M12)	-	55	-	M12	3
N CNW 854 / 250	300	-	160	-	270	224	95	10 x 18	25 (M12)	-	55	-	M12	3
N CNW 854 / 300	360	-	180	-	315	264	137	10 x 18	-	30 x 4	40	11	M12	4
N CNW 854 / 350	360	-	200	-	315	264	142	10 x 18	-	40 x 5	50	13	M12	4
N CNW 854 / 400	360	-	215	-	315	264	157	10 x 18	-	40 x 5	50	13	M12	4
N CNW 854 / 500	360	-	225	-	315	264	167	10 x 18	-	40 x 5	50	13	M12	4
N CNW 854 / 600	420	-	215	-	365	316	144	13 x 20	-	40 x 8	60	13	M12	4
N CNW 854 / 700	420	-	245	-	365	316	174	13 x 20	-	40 x 8	60	13	M12	4
N CNW 854 / 800	420	-	255	-	480	316	174	13 x 20	-	60 x 5	70	2 x 13	M12	4
N CNW 854 / 900	420	-	265	-	480	316	174	13 x 20	-	60 x 10	80	2 x 13	M12	4
N CNW 854 / 1000	420	-	265	-	480	316	174	13 x 20	-	60 x 10	80	2 x 13	M12	4
N CNW 854 / 1200	420	-	275	-	480	316	184	13 x 20	-	60 x 10	80	2 x 13	M12	4

Design 1

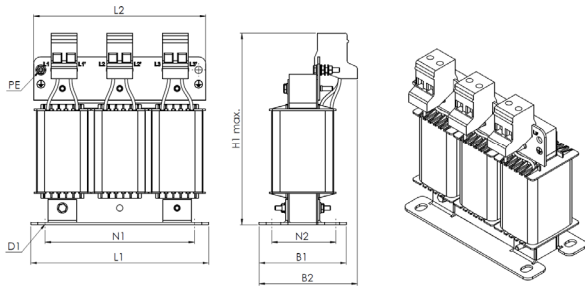

Design 2

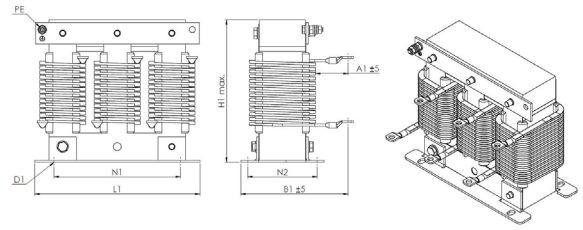

Design 3

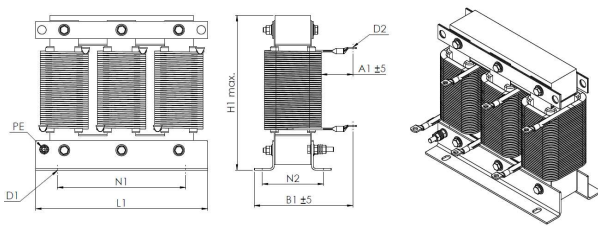

Design 4

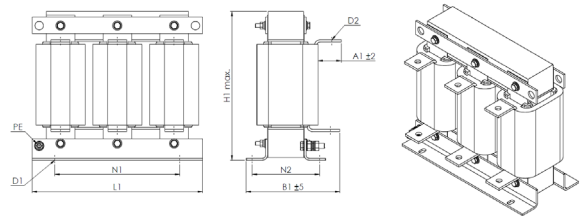

# CNW M 854

Fully cast three-phase motor choke

## Advantages

- Use in harsh environments
- IP 66
- Connection options include: Cables, Clamps, Terminals
- Customer-specific mounting plate possible
- Lower surface temperature
- Protection for electrical loads
- Limitation of voltage rise to < 500 V/μs
- Extended service life for electrical loads
- Reduction of audible motor noise
- Low leakage currents at the motor
- Longer motor cables possible
- Easy assembly and compact design
- Production according to UL insulation system E251513 possible

## Description

- Nominal voltage:  $U \leq 3 \times 500 \text{ V}$
- Reduction of the voltage rise DV/DT to < 200 V/μs
- Rotating field frequency: 0 - 60 Hz
- Clock frequency of the inverter: up to 150 A > 4 kHz, from 150 A > 1.5 kHz
- According to: EN 60289 / EN 61558
- Test voltage: L-L 2500 V, AC/50 Hz 60s; L-PE 2500 V, AC/50 Hz 60s
- Insulation class: T40/F
- Protection class: IP 66
- Climate category: DIN IEC 60068-1
- Overload:  $1.5 \times I_{\text{Rated}}$  1 min/h
- Ambient temperature 40 °C
- Design: Mounted on brackets



## Technical details

CNW M 854						
Type	Nominal voltage [V]	Nominal current [A]	Inductance [mH]	Copper [kg]	Weight [kg]	Cables [mm²]
CNW M 854 / 6	up to 3 x 500	6	2,3	0,5	1,7	1,5
CNW M 854 / 8		8	2,0	0,5	1,7	1,5
CNW M 854 / 10		10	1,7	0,9	2,8	1,5
CNW M 854 / 12		12	1,1	1,1	3,7	1,5
CNW M 854 / 16		16	0,9	1,1	3,7	2,5
CNW M 854 / 24		24	0,8	1,7	4,6	4,0
CNW M 854 / 30		30	0,5	1,7	4,6	4,0
CNW M 854 / 37		37	0,4	2,1	7,2	6,0



Typical applications: Drive systems for motor drives, mechanical engineering, elevators / escalators, pipes, conveyor technology, ventilation and air conditioning, robotics, automation technology, power supplies, wind turbines

## Dimensions in mm

CNW M 854												
Type	L1 (mm)	B1 (mm)	H1 (mm)	Bolting	Clamp	L2 (mm)	L3 (mm)	B2 (mm)	H2 (mm)	N1 (mm)	N2 (mm)	ØD (mm)
CNW M 854/6	185	80	57	M20	4mm <sup>2</sup>	115	100	74	88	80	60	5,5 x 7,0
CNW M 854/8	185	80	57	M20	4mm <sup>2</sup>	115	100	74	88	80	60	5,5 x 7,0
CNW M 854/10	185	80	57	M20	4mm <sup>2</sup>	140	125	77	113	100	60	5,5 x 7,0
CNW M 854/12	185	80	57	M20	4mm <sup>2</sup>	140	125	87	113	100	70	5,5 x 7,0
CNW M 854/16	185	80	57	M20	6mm <sup>2</sup>	140	125	87	113	100	70	5,5 x 7,0
CNW M 854/24	190	80	57	M25	6mm <sup>2</sup>	175	155	99	137	130	79	5,5 x 7,0
CNW M 854/30	190	80	57	M25	16mm <sup>2</sup>	175	155	99	137	130	79	5,5 x 7,0
CNW M 854/37	190	80	57	M25	16mm <sup>2</sup>	175	155	114	137	130	94	5,5 x 12,0

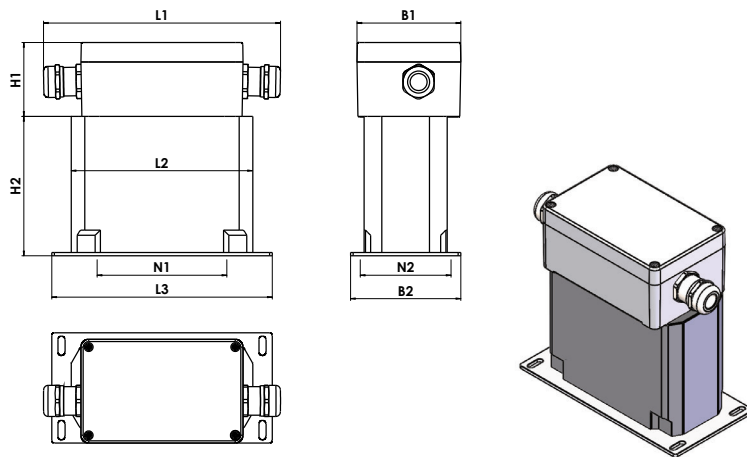

# CNW 931

Single-phase sinusoidal filter 6.15 %  $U_k$

## Advantages

- Minimal thermal losses
- Low noise
- Production according to UL insulation system 251513 possible
- Easy connection
- Use with motor cables up to 1000 meters possible
- Reduction in use of shielded cable possible

## Description

- Ambient temperature 50 °C)
- Protection class: IP 00
- Insulation class: F
- Linearity: LN at 1.2 x IN u.  $\geq 0.8 \times$  LN by 1.5 x IN
- Test voltage: 3 kV
- Nominal voltage: 230 V
- $U_k$ : 6.15 %
- Overvoltage category: 2
- Level of contamination 2
- Cooling: TO
- Switching frequency:  $\geq 4$  kHz
- Current ripple  $\leq 20$  % at 4 kHz

CNW 931



## Technical details

CNW 931									
Type	Nominal current [A]	Inductance [mH]	Resistance R20 [mΩ]	Kapazität [μF]	Capacitance [W]	$U_k$ @ 230 V	$U_k$ @ 133 V	$U_k$ @ 400 V	Copper [kg]
CNW 931 / 3	3	15	349,5	6,8	17	6,2 %	10,6 %	3,5 %	0,15
CNW 931 / 4	4	11,3	275,2	10	22	6,2 %	10,7 %	3,6 %	0,23
CNW 931 / 6	6	7,5	133,1	10	29	6,2 %	10,6 %	3,5 %	0,29
CNW 931 / 8	8	5,6	94,4	20	33	6,1 %	10,6 %	3,5 %	0,33
CNW 931 / 10	10	4,5	62,2	20	37	6,2 %	10,6 %	3,5 %	0,53
CNW 931 / 12	12	3,75	59,9	20	43	6,2 %	10,6 %	3,5 %	0,64
CNW 931 / 16	16	2,8	43,4	20	56	6,1 %	10,6 %	3,5 %	0,82



Typical applications: Drive systems for motor drives, mechanical engineering, elevators / escalators, pipes, conveyor technology, ventilation and air conditioning, robotics, automation technology, power supplies, wind turbines

## Dimensions in mm

CNW 931								
Type	L [mm]	B1 [mm]	B2 [mm]	H [mm]	N1 [mm]	N2 [mm]	Clamp [mm <sup>2</sup> ]	Weight [kg]
CNW 931 / 3	64	72	59	115	44	47	1,5 mm <sup>2</sup>	0,9
CNW 931 / 4	66	74	64	130	50	49	1,5 mm <sup>2</sup>	1,1
CNW 931 / 6	83	80	69	153	56	56	1,5 mm <sup>2</sup>	1,8
CNW 931 / 8	83	80	69	153	56	56	2,5 mm <sup>2</sup>	1,9
CNW 931 / 10	84	90	84	160	71	71	2,5 mm <sup>2</sup>	2,5
CNW 931 / 12	96	86	86	170	80	71	2,5 mm <sup>2</sup>	3
CNW 931 / 16	96	110	110	170	80	95	2,5 mm <sup>2</sup>	4,4

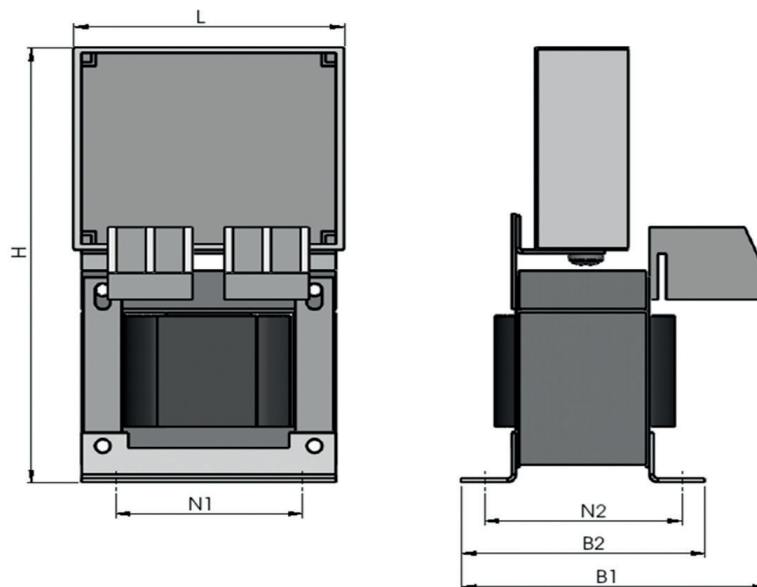

# N CNW 933

Three phase sinusoidal filter

## Advantages

- Output voltage is sinusoidal
- DV/DT is eliminated
- High damping of interference emissions from the lines
- Effective against symmetrical disturbances
- Motor cables up to 1000 m possible
- Savings in shielded cable possible
- Extended service life for electrical loads
- Reduction of motor noises
- Low leakage currents at the motor
- Easy assembly
- Production according to UL insulation system E251513 possible

## Description

- Nominal voltage:  $U \leq 3 \times 500 \text{ V}$
- Max. voltage ripple: 5 %
- Rotating field frequency: 0 - 60 Hz
- Clock frequency of the inverter: up to 150 A > 4 kHz, from 150 A > 1.5 kHz
- Short-circuit voltage UK: 8 % (at 400V)
- Voltage drop: 18.4 V/strand (at IRated and 50 Hz)
- Max length of supply cable to motor: 600m (unshielded) 1000m (shielded)
- According to: EN 60289 / EN 61558
- Test voltage: L-L 2500 V, AC/50 Hz 60s; L-PE 2500 V, AC/50 Hz 60s
- Insulation class: T40/F
- Protection class: IP 00
- Climate category: DIN IEC 60068-1
- Overload: 1.5 x IRated 1 min/h
- Ambient temperature 40 °C)
- Design: Mounted on brackets

N CNW 933

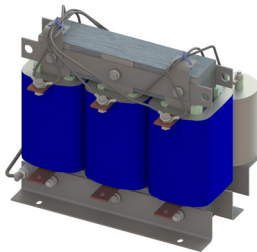



# Technical details

N CNW 933								
Type	Nominal voltage U [V]	Nominal current I [A]	Inductance L [mH]	Capacitance C [µF]	Losses P [W]	Weight [kg]	Weight Cu [kg]	Weight Al [kg]
N CNW 933 / 2	500 50 / 60 Hz	2	25	0,1	37	1,15	0,5	-
N CNW 933 / 4		4	12,5	0,33	30	2,4	0,9	-
N CNW 933 / 6		6	7,5	0,33	40	2,9	0,8	-
N CNW 933 / 8		8	5,8	0,73	65	3,0	1,0	-
N CNW 933 / 10		10	5,6	1,1	50	4,6	1,9	-
N CNW 933 / 12		12	4,7	1,5	60	6,3	2,3	-
N CNW 933 / 16		16	3,4	1,5	167	7,8	3,4	-
N CNW 933 / 20		20	2,9	1,5	212	9,3	3,3	-
N CNW 933 / 24		24	2,4	2,2	85	11,0	3,6	-
N CNW 933 / 30		30	1,9	2,2	240	16,0	7,4	-
N CNW 933 / 37		37	1,6	3,3	160	22,5	8,0	-
N CNW 933 / 48		48	1,2	4,7	190	22,0	8,0	-
N CNW 933 / 60		60	0,95	6,8	230	27,0	10,0	-
N CNW 933 / 75		75	0,79	6,8	225	34,0	13,8	-
N CNW 933 / 90		90	0,68	8,0	317	40,0	12,6	-
N CNW 933 / 115		115	0,51	12,0	320	60,0	25,6	-
N CNW 933 / 120		120	0,5	18,0	340	58,0	0,9	6,6
N CNW 933 / 150		150	0,326	40,0	310	61,0	1,1	7,1
N CNW 933 / 180		180	0,325	40,0	390	76,0	1,1	8,0
N CNW 933 / 200		200	0,293	47,0	550	79,0	1,5	6,0
N CNW 933 / 250		250	0,236	68,0	620	89,0	1,5	6,9
N CNW 933 / 350		350	0,167	68,0	810	104,0	3,2	11,3
N CNW 933 / 400		400	0,146	120	980	106,0	3,2	11,3
N CNW 933 / 450		450	0,130	120	1210	181,0	3,2	14,8
N CNW 933 / 500		500	0,118	120	1420	208,0	3,8	15,3
N CNW 933 / 600		600	0,098	180	1590	227,0	7,1	17,6
N CNW 933 / 700		700	0,085	180	1570	258,0	7,1	30,1
N CNW 933 / 750		750	0,078	220	1750	259,0	7,1	30,1
N CNW 933 / 800		800	0,074	220	1910	297,0	6,7	28,8
N CNW 933 / 900		900	0,065	240	2360	315,0	14,2	29,4
N CNW 933 / 1000	1000	0,059	240	2610	370,0	14,2	28,4	
N CNW 933 / 1200	1200	0,05	360	2980	417,0	14,2	33,4	



Typical applications: Drive systems for motor drives, mechanical engineering, elevators / escalators, pipes, conveyor technology, ventilation and air conditioning, robotics, automation technology, power supplies, wind turbines

## Dimensions in mm

N CNW 933														
Type	Length		Width		Height	Mounting			Clamps/ Cross section [mm <sup>2</sup> ]	Connection				Design
	L1 [mm]	L2 [mm]	B1 [mm]	B2 [mm]	H1 [mm]	N1 [mm]	N2 [mm]	D1 [mm x mm]		Angle [mm x mm]	A1 [mm]	D2 [mm]	PE Ø [mm]	
N CNW 933 / 2	80	96	45	56,5	110	56	34	5 x 8	1,5	-	-	-	Flat plug 6,3x0,8	1
N CNW 933 / 4	125	-	61	-	167	100	43	5 x 8	2,5	-	-	-	2,5	2
N CNW 933 / 6	125	-	72	-	175	100	56	5 x 8	2,5	-	-	-	2,5	2
N CNW 933 / 8	125	-	72	-	175	100	56	5 x 8	2,5	-	-	-	2,5	2
N CNW 933 / 10	155	-	77	-	205	130	57	8 x 12	10	-	-	-	10	2
N CNW 933 / 12	155	-	92	-	205	130	72	8 x 12	10	-	-	-	10	2
N CNW 933 / 16	190	-	82	-	235	170	58	8 x 12	10	-	-	-	10	2
N CNW 933 / 20	190	-	125	-	215	170	68	8 x 12	10	-	-	-	10	3
N CNW 933 / 24	190	-	135	-	215	170	78	8 x 12	10	-	-	-	10	3
N CNW 933 / 30	230	-	130	-	255	176	71	9 x 13	10	-	-	-	10	3
N CNW 933 / 37	240	-	160	-	275	185	85	10 x 18	16	-	-	-	16	3
N CNW 933 / 48	240	-	170	-	285	185	95	10 x 18	16	-	-	-	16	3
N CNW 933 / 60	240	-	180	-	285	185	105	10 x 18	35	-	-	-	35	4
N CNW 933 / 75	300	-	186	-	355	224	94	10 x 18	50	-	-	-	50	4
N CNW 933 / 90	300	-	205	-	350	224	119	10 x 18	50	-	-	-	50	4
N CNW 933 / 115	360	-	220	-	410	264	127	10 x 18	95	-	-	-	95	4
N CNW 933 / 120	360	-	267	183	395	264	157	10 x 18	-	25 x 3	32	9	M10	5
N CNW 933 / 150	360	-	306	183	350	264	157	10 x 18	-	30 x 3	37	11	M10	5
N CNW 933 / 180	360	-	330	213	396	264	187	10 x 18	-	30 x 3	37	11	M10	5
N CNW 933 / 200	360	-	339	213	375	264	187	10 x 18	-	30 x 4	39	11	M10	5
N CNW 933 / 250	360	-	348	223	390	264	197	10 x 18	-	30 x 4	39	11	M10	5
N CNW 933 / 350	480	-	338	204	480	356	168	13 x 20	-	40 x 5	49	13	M12	5
N CNW 933 / 400	480	-	359	204	480	356	168	13 x 20	-	40 x 5	49	13	M12	5
N CNW 933 / 450	480	-	434	274	485	356	238	13 x 20	-	40 x 5	49	13	M12	5
N CNW 933 / 500	540	-	423	294	510	360	228	13 x 20	-	40 x 5	49	13	M12	5
N CNW 933 / 600	540	-	433	294	550	360	228	13 x 20	-	40 x 5	59	13	M12	5
N CNW 933 / 700	580	-	442	274	575	400	228	13 x 20	-	40 x 5	59	13	M12	5
N CNW 933 / 750	580	-	442	274	580	400	228	13 x 20	-	40 x 5	59	13	M12	5
N CNW 933 / 800	580	-	470	294	570	400	248	13 x 20	-	60 x 5	69	13	M12	5
N CNW 933 / 900	680	-	345	264	650	480	211	13 x 20	-	60 x 10	79	2 x 13	M12	6
	300	-	500	-	245	250	475	9 x 13	-	-	-	11	M8	7
N CNW 933 / 1000	680	-	375	294	655	480	241	13 x 20	-	60 x 10	79	2 x 13	M12	6
	300	-	500	-	245	250	475	9 x 13	-	-	-	11	M8	7
N CNW 933 / 1200	680	-	395	314	660	480	261	13 x 20	-	60 x 10	79	2 x 13	M12	6
	450	-	500	-	245	400	475	9 x 13	-	-	-	11	M8	7

Design 1

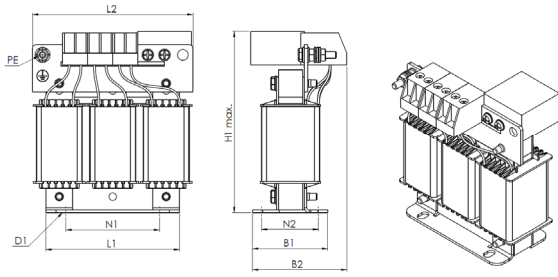

Design 2

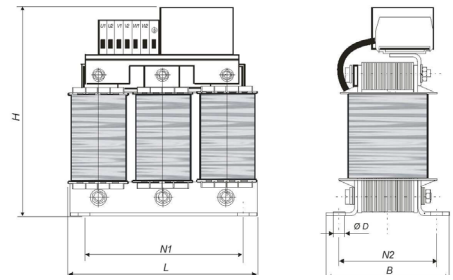

Design 3

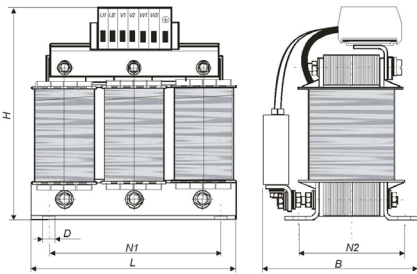

Design 4

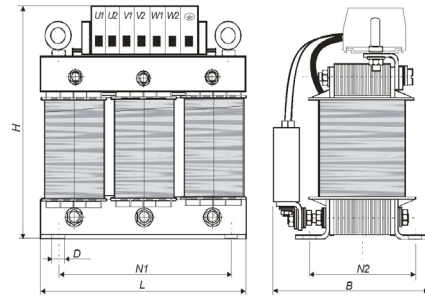

Design 5

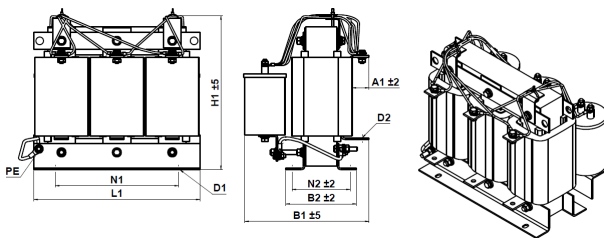

Design 6

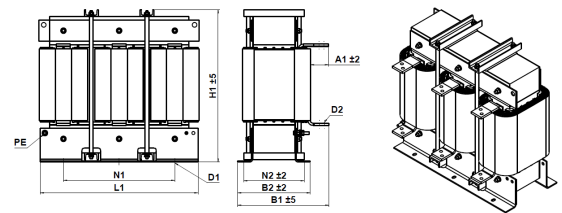

Design 7

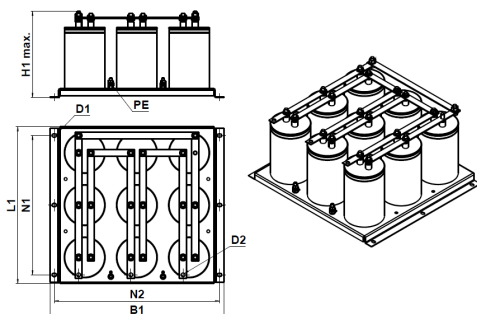

# CNW M 933

Three-phase sinusoidal filter

## Advantages

- Use in harsh environments
- Optimum mechanical protection of the choke
- Upgrade to IP 66 possible
- Various connection options
- Customer-specific mounting plate possible
- Lower surface temperature
- Output voltage is sinusoidal
- Greatly reduced DV/DT
- High damping of interference emissions from the lines
- Motor cables up to 1000 m possible
- Extended service life for electrical loads
- Production according to UL insulation system E251513 possible

## Description

- Nominal voltage:  $U \leq 3 \times 500 \text{ V}$
- Max. voltage ripple: 5 %
- Rotating field frequency: 0 - 60 Hz
- Clock frequency of the inverter: up to 150 A > 4 kHz, from 150 A > 1.5 kHz
- Short-circuit voltage UK: 8 % (at 400 V)
- Voltage drop: 18.4 V/strand (at  $I_{\text{Rated}}$  and 50 Hz)
- Max. length of supply cable to motor: 600 m (unshielded) 1000 m (shielded)
- According to: EN 60289 / EN 61558
- Test voltage: L-L 2500 V, AC/50 Hz 60s; L-PE 2500 V, AC/50 Hz 60s
- Insulation class: T40/F
- Protection class: IP 00
- Climate category: DIN IEC 60068-1
- Overload:  $1.5 \times I_{\text{Rated}}$  1 min/h
- Ambient temperature 40 °C)
- Design: Constructed on mounting plate



# Technical details

CNW M 933							
Type	Nominal voltage [V]	Nominal current [A]	Inductance [mH]	Capacitance [µF]	Copper weight [kg]	Weight [kg]	Strand [mm²]
CNW M 933 / 2	up to 3 x 500	2	29,3	0,22	0,9	2,9	1,5
CNW M 933 / 4		4	14,6	0,33	0,9	2,9	1,5
CNW M 933 / 6		6	9,7	0,73	1,0	3,6	1,5
CNW M 933 / 8		8	5,3	0,73	1,0	3,6	1,5
CNW M 933 / 10		10	5,0	0,73	1,8	5,8	1,5
CNW M 933 / 12		12	4,9	1,1	2,3	7,5	1,5
CNW M 933 / 16		16	3,6	1,1	3,2	9,0	2,5
CNW M 933 / 20		20	2,9	1,5	3,6	13,0	4,0
CNW M 933 / 24		24	2,4	2,2	3,6	13,0	4,0
CNW M 933 / 30		30	2,0	2,2	10,0	28,0	6,0
CNW M 933 / 37		37	1,9	3,3	11,0	29,0	6,0



Typical applications: Drive systems for motor drives, mechanical engineering, elevators / escalators, pipes, conveyor technology, ventilation and air conditioning, robotics, automation technology, power supplies, wind turbines

## Dimensions in mm

CNW M 933													
Type	L1 (mm)	B1 (mm)	H1 (mm)	Bolting	Clamp	Protection class	L2 (mm)	L3 (mm)	B2 (mm)	H2 (mm)	N1 (mm)	N2 (mm)	ØD (mm)
CNW M 933/2	185	80	57	M20	4mm²	IP66	140	125	77	113	100	60	5,5 x 7,0
CNW M 933/4	185	80	57	M20	4mm²	IP66	140	125	77	113	100	60	5,5 x 7,0
CNW M 933/6	185	80	57	M20	4mm²	IP66	140	125	87	113	100	70	5,5 x 7,0
CNW M 933/8	185	80	57	M20	4mm²	IP66	140	125	87	113	100	70	5,5 x 7,0
CNW M 933/10	200	80	80	M20	4mm²	IP64	175	155	99	137	130	79	5,5 x 12,0
CNW M 933/12	200	80	80	M20	4mm²	IP64	175	155	114	137	130	94	5,5 x 12,0
CNW M 933/16	200	120	100	M20	6mm²	IP64	195	200	125	165	165	100	9,0 x 13,0
CNW M 933/20	200	120	100	M25	6mm²	IP64	195	200	145	165	165	120	9,0 x 13,0
CNW M 933/24	200	120	100	M25	6mm²	IP64	195	200	145	165	165	120	9,0 x 13,0
CNW M 933/30	210	120	110	M32	16mm²	IP64	250	255	180	220	185	150	9,0 x 13,0
CNW M 933/37	210	120	110	M32	16mm²	IP64	250	255	180	220	185	150	9,0 x 13,0

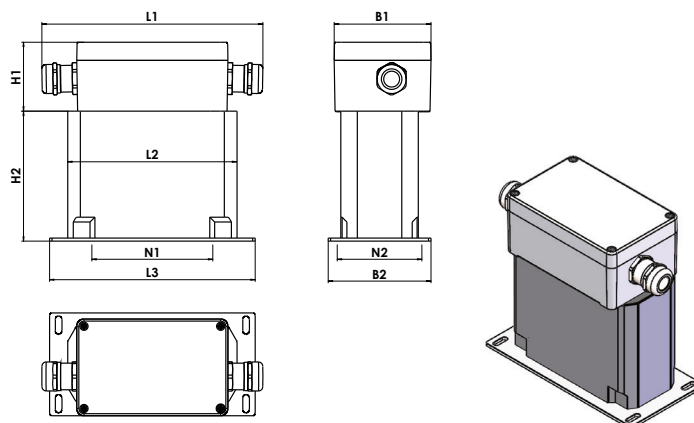

# CNW 961

Three-phase sinusoidal filter Plus<sup>++</sup>

## Advantages

- Distortion factor U off < 5%
- Use of unshielded cables is possible
- Low EMC interference from parallel conductors
- Simple internal EMC filter sufficient in the frequency converter
- No external mains filters required
- Compact and low-noise

## Description

- According to: EN 61558-2-20
- Test voltage: L-L 1000 V, DC 1 min; L-PE 2500 V, DC 1 min
- Nominal voltage: U = 3 x 500 V
- Insulation class: T40/B
- Climate category: DIN IEC 60068-1
- Overload: 1.5 x I<sub>Rated</sub> 1 min/h



## Technical details

CNW 961						
Type	Nominal voltage [V]	Nominal current [A]	Inductance Total [mH]	Capacitance [µF]	Copper [kg]	Weight [kg]
CNW 961 / 2	up to 3 x 500	2	33,4	0,11	1,4	5,2
CNW 961 / 4		4	16,7	0,34	1,7	5,5
CNW 961 / 6		6	11,0	0,50	3,0	5,8
CNW 961 / 10		10	6,60	1,10	4,5	9,1
CNW 961 / 16		16	4,20	1,10	5,0	13,0
CNW 961 / 24		24	2,83	1,50	6,5	17,3
CNW 961 / 30		30	2,20	2,20	12,0	37,0
CNW 961 / 37		37	1,64	2,20	12,5	38,0
CNW 961 / 48		48	1,41	3,30	16,2	42,0
CNW 961 / 60		60	0,91	4,70	17,0	62,0



Minimum clock frequency 8 kHz. The inverter load is increased by feedback into the DC Link. Please check if the inverter is suitable for this!

Typical applications: Water treatment - in particular heat pumps and material safety in general. With the REO Sinusoidal Filter Plus<sup>++</sup>, not only the mains leads to the motor, are suppressed but also the Earth conductor. Bearing currents generated in the motor are fed through the REO Sinusoidal Filter Plus<sup>++</sup> into the DC link so that they cannot cause mechanical damage. The REO Sinusoidal Filters Plus<sup>++</sup> are used wherever safe continuous mechanical performance and reliability are required.

# Dimensions in mm

CNW 961										
Type	Dimensions							Connections		
	L1 [mm]	L2 [mm]	B1 [mm]	B2 [mm]	H [mm]	Ø D1 [mm]	Ø D2 [mm]	PE-Bolt [mm]	Converter [Clamp]	Motor [Clamp]
CNW 961 / 2	366	351	90	60	175	7	7 x 10	M6	4 mm <sup>2</sup>	4 mm <sup>2</sup>
CNW 961 / 4	366	351	90	60	175	7	7 x 10	M6	4 mm <sup>2</sup>	4 mm <sup>2</sup>
CNW 961 / 6	366	3541	90	60	175	7	7 x 10	M6	4 mm <sup>2</sup>	4 mm <sup>2</sup>
CNW 961 / 10	470	455	90	60	175	7	7 x 10	M6	4 mm <sup>2</sup>	4 mm <sup>2</sup>
CNW 961 / 16	525	500	150	110	190	9 x 15	9 x 15	M6	4 mm <sup>2</sup>	4 mm <sup>2</sup>
CNW 961 / 24	655	630	150	110	190	9 x 17	9 x 17	M6	6 mm <sup>2</sup>	6 mm <sup>2</sup>
CNW 961 / 30	608	584	300	200	230	9 x 17	9	M6	16 mm <sup>2</sup>	16 mm <sup>2</sup>
CNW 961 / 37	608	584	300	200	230	9 x 17	9	M6	16 mm <sup>2</sup>	16 mm <sup>2</sup>
CNW 961 / 48	620	570	300	200	245	9	9	M6	16 mm <sup>2</sup>	16 mm <sup>2</sup>
CNW 961 / 60	620	570	350	250	242	9	9	M6	25 mm <sup>2</sup>	25 mm <sup>2</sup>

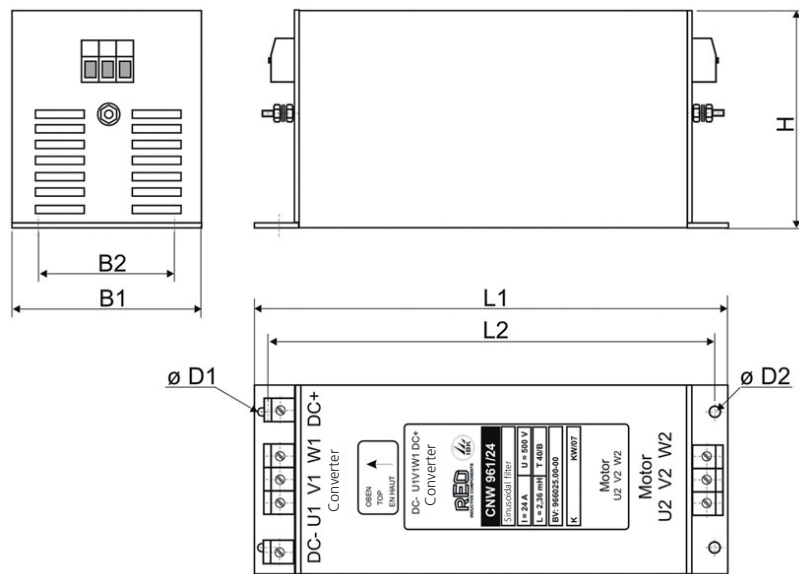





REO

## EMC-Filter



# EMC-Filter

Useful facts	P. 51
CNW 101	P. 52-53
CNW 102	P. 54-55
N CNW 103	P. 56-57
CNW 107.3	P. 58-59
N CNW 114	P. 60-61
N CNW 105	P. 62-63

## Useful facts about EMC-Filter

### The propagation of interference

The use of electrical and electrical equipment is becoming more widespread. However to ensure safe and reliable operation, electromagnetically compatible conditions must exist i.e. a device must be able to work satisfactorily in its electromagnetic environment and without itself causing unacceptable electromagnetic interference in the same environment. Electromagnetic interference can cause various faults that are often difficult to diagnose. Crackling and hissing on a radio receiver, data errors and processor glitches in computer engineering and even the breakdown of isolation are all possible effects. To ensure compliance with relevant EMC directives and to avoid instances of interference, appropriate EMC filters must be used. Electromagnetic interference can be propagated in various ways. The nature of that propagation depends on the frequency involved.

Important:

- Low frequency interference <10 MHz is mainly propagated by parasitic electromagnetic coupling
- Higher frequency interference > 30 MHz is mostly radiated

Frequencies between usually experience a combination of both propagation mechanisms.

# CNW 101

Single-phase mains filter, single-stage

## Advantages

- Small dimensions
- Quick connection
- Touch-proof if used with insulated spade connectors
- Good damping performance at a low leakage current
- Also available as a medical version or with a lower leakage current
- Optional with overvoltage protection
- UL approval for the complete model range - E217177 (not for N- and MED-versions)

CNW 101

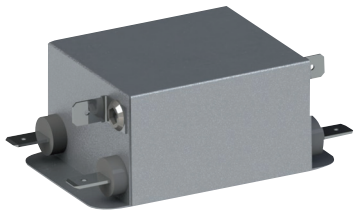

## Technical data

CNW 101							
Type	Rated voltage [V]	Rated current [A]	Leakage current [mA]	Cx [ $\mu$ F]	Cy [nF]	L [mH]	R [kOhm]
CNW 101/3	250	3	<3,5	0,94	20	3,3	560
CNW 101/6	250	6	<3,5	0,94	20	1,8	560
CNW 101/10	250	10	<3,5	0,94	20	1,8	560
CNW 101/16	250	16	<3,5	0,94	20	1,2	560
CNW 101/20	250	20	<3,5	0,94	20	1,0	560
CNW 101/3/N	250	3	<0,5	0,94	4,4	3,3	560
CNW 101/6/N	250	6	<0,5	0,94	4,4	1,8	560
CNW 101/10/N	250	10	<0,5	0,94	4,4	1,8	560
CNW 101/16/N	250	16	<0,5	0,94	4,4	1,2	560
CNW 101/20/N	250	20	<0,5	0,94	4,4	1,0	560
CNW 101/3/MED	250	3	<0,005	0,94	-	3,3	560
CNW 101/6/MED	250	6	<0,005	0,94	-	1,8	560
CNW 101/10/MED	250	10	<0,005	0,94	-	1,8	560
CNW 101/16/MED	250	16	<0,005	0,94	-	1,2	560
CNW 101/20/MED	250	20	<0,005	0,94	-	1,0	560



Typical applications: Inverter applications, switch-mode power supplies for industrial electronics, telecommunications information technology, medical applications

# Dimensions in mm

CNW 101								
Type	Connection	PE-Connection	Dimensions [mm]					
			B	D	H	L 1	L 2	L 3
CNW 101/3	Flat plug 6,3x0,8		45	4,2	30	70	60	52
CNW 101/6	Flat plug 6,3x0,8		45	4,2	30	70	60	52
CNW 101/10	Flat plug 6,3x0,8		50	5,3	30	85	75	65
CNW 101/16	Flat plug 6,3x0,8		50	5,3	30	85	75	65
CNW 101/20	Flat plug 6,3x0,8		50	5,3	30	85	75	65

Attenuation curve CNW 101/16\*

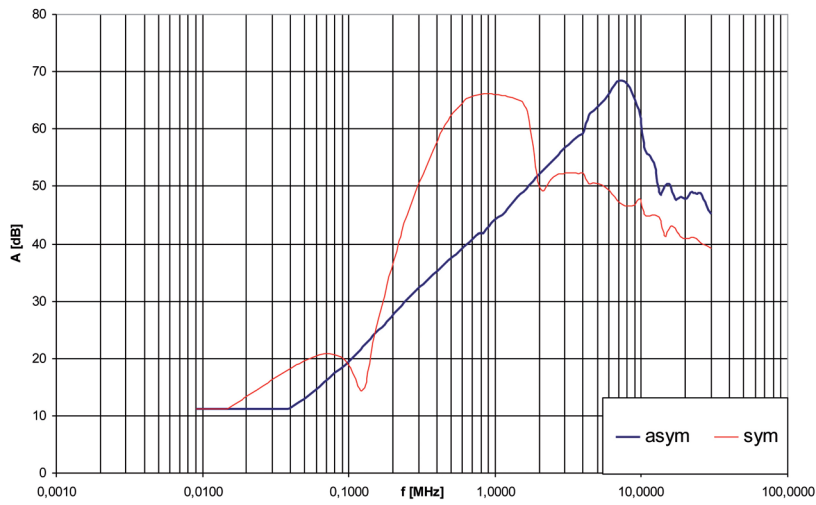

\*For additional attenuation curves, please refer to our data sheet.

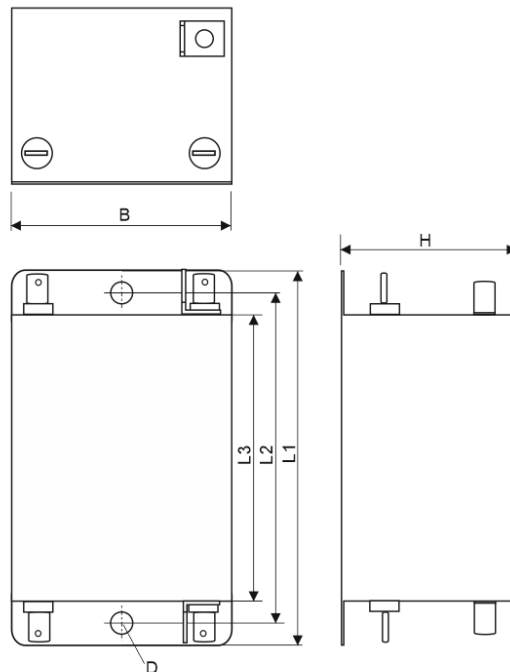

# CNW 102

Single phase mains filter, two-stage

CNW 102

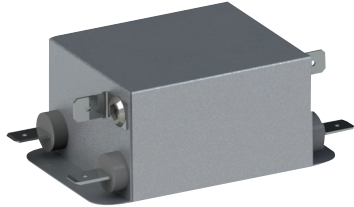

## Advantages

- Small dimensions
- Quick connection
- touch-proof if used with insulated spade connectors
- very good damping performance at a low leakage current
- also as a medical version or with a lower leakage current available
- optional with overvoltage protection
- UL approval for the complete model range - E217177 (except N- and MED-versions)

## Technical data

CNW 102							
Type	Rated voltage [V]	Rated current [A]	Leakage current [mA]	Cx [ $\mu$ F]	Cy [nF]	L [mH]	R [kOhm]
CNW 102/3	250	3	<3,5	0,94	20	13,6	560
CNW 102/6	250	6	<3,5	0,94	20	7,8	560
CNW 102/10	250	10	<3,5	0,94	20	3,6	560
CNW 102/16	250	16	<3,5	0,94	20	2,4	560
CNW 102/20	250	20	<3,5	0,94	20	2,0	560
CNW 102/3/N	250	3	<0,5	0,94	4,4	13,6	560
CNW 102/6/N	250	6	<0,5	0,94	4,4	7,8	560
CNW 102/10/N	250	10	<0,5	0,94	4,4	3,6	560
CNW 102/16/N	250	16	<0,5	0,94	4,4	2,4	560
CNW 102/20/N	250	20	<0,5	0,94	4,4	2,0	560
CNW 102/3/MED	250	3	<0,005	0,94	-	13,6	560
CNW 102/6/MED	250	6	<0,005	0,94	-	7,8	560
CNW 102/10/MED	250	10	<0,005	0,94	-	3,6	560
CNW 102/16/MED	250	16	<0,005	0,94	-	2,4	560
CNW 102/20/MED	250	20	<0,005	0,94	-	2,0	560



Typical applications: Switch-mode power supplies for industrial electronics, frequency converters for motor drives, power supply units, medical and telecommunication applications, DC applications

# Dimensions in mm

CNW 102								
Type	Connection	PE-Connection	Dimensions [mm]					
			B	D	H	L 1	L 2	L 3
CNW 102/3	Flat plug 6,3x0,8		50	5,3	40	87	75	65
CNW 102/6	Flat plug 6,3x0,8		50	5,3	40	87	75	65
CNW 102/10	Flat plug 6,3x0,8		50	5,3	40	87	75	65
CNW 102/16	Flat plug 6,3x0,8		53	5,3	40	110	100	90
CNW 102/20	Flat plug 6,3x0,8		53	5,3	40	110	100	90

Attenuation curve CNW 101/16\*

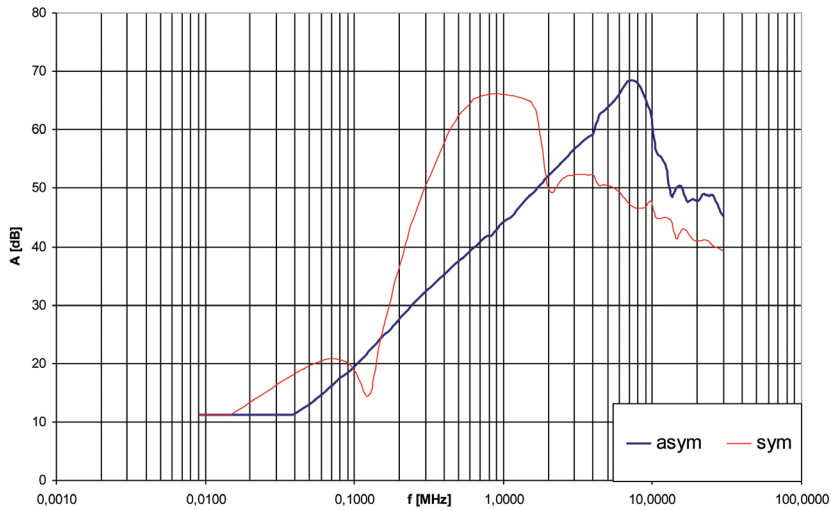

\*For additional attenuation curves, please refer to our data sheet

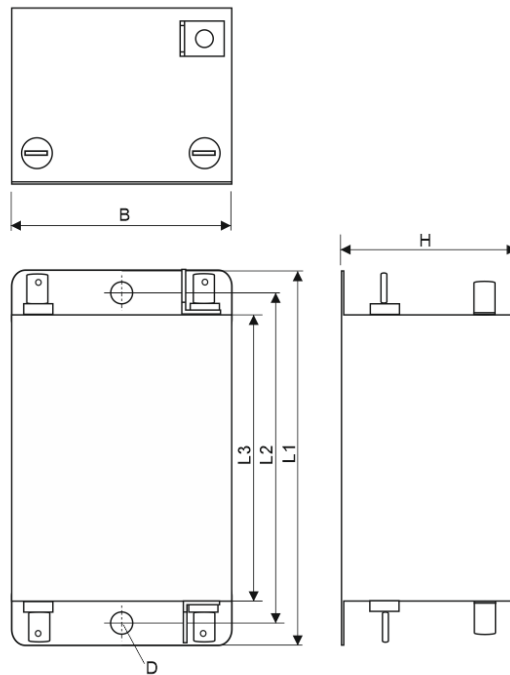

# N CNW 103

Three phase mains filter, single-stage, three wire

N CNW 103

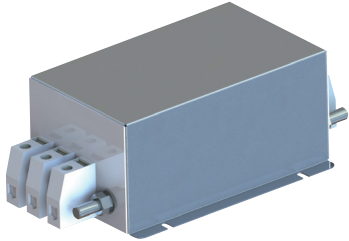

## Advantages

- Small dimensions
- Quick connection
- Low temperature rise
- Touch-proof terminals
- Good damping performance at a low leakage current
- Useable for industrial applications

## Technical data

N CNW 103								
Type	Rated voltage [V]	Rated current [A]	Leakage current [mA]	Cx [ $\mu$ F]	Cy [nF]	L [mH]	R [kOhm]	Frequency [Hz]
CNW 103/3	3x500	3x3	<1	0,5	30	3,0	1,12	50/60 Hz
CNW 103/6		3x6		0,5		2,2		
CNW 103/10		3x10		0,5		1,7		
N CNW 103/16		3x16		1,0	39	1,5		
N CNW 103/25		3x25		1,0		1,2		
N CNW 103/36		3x36		<1,5	60	1,5		
N CNW 103/50		3x50	2,2			0,9		
N CNW 103/80		3x80	<5	2,75	197	0,25		
N CNW 103/120		3x120				0,8		
N CNW 103/150		3x150				0,8		
N CNW 103/180		3x180				0,8		



Typical applications: Frequency converters for motor drives e.g. lifts, materials handling, pumps, ventilation and air-conditioning systems, industrial applications, wind power installations and power supply units



# Dimensions in mm

N CNW 103											
Type	Housing	Connection	PE-Connection	Dimensions [mm]							
				B1 [mm]	B2 [mm]	B3 [mm]	D [mm]	H [mm]	L 1 [mm]	L 2 [mm]	L 3 [mm]
CNW 103/3	A	Flat plug 6,3 mm	AMP flat plug	53	-	-	5,3	40	110	100	90
CNW 103/6				53	-	-	5,3	40	110	100	90
CNW 103/10				53	-	-	5,3	40	110	100	90
N CNW 103/16	B	Clamps 4mm <sup>2</sup>	Earthing bolt (M6)	98	80	70	5,0	70	177	150	90
N CNW 103/25		Clamps 6mm <sup>2</sup>		98	80	70	5,0	70	179	150	90
N CNW 103/36		Clamps 10mm <sup>2</sup>		148	135	120	7,0	70	229	200	160
N CNW 103/50		Clamps 16mm <sup>2</sup>	148	135	120	7,0	70	238	200	160	
N CNW 103/80		Clamps 25mm <sup>2</sup>	Earthing bolt (M10)	168	155	140	7,0	90	303	240	160
N CNW 103/120		Clamps 50mm <sup>2</sup>	Earthing bolt (M12)	168	155	140	7,0	90	331	240	160
N CNW 103/150		Clamps 95mm <sup>2</sup>		168	155	140	7,0	90	331	240	160
N CNW 103/180		Clamps 95mm <sup>2</sup>		168	155	140	7,0	90	339	240	160

Housing A

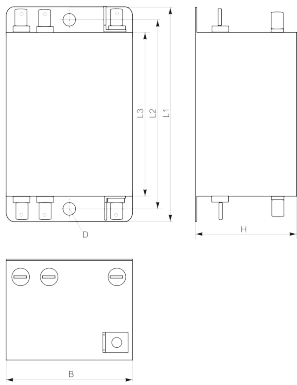

Housing B

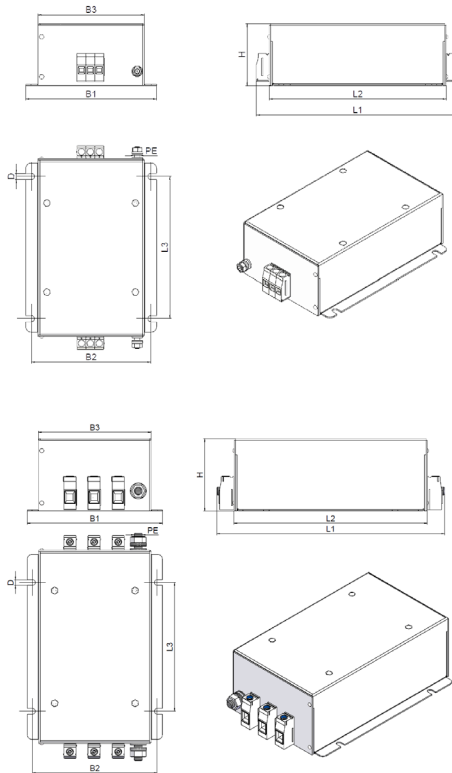

Connections

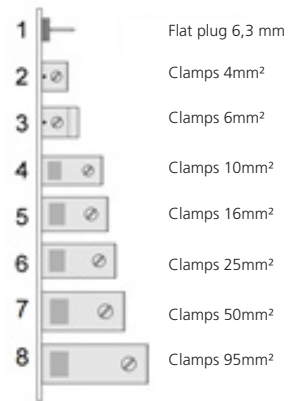

PE-Connections

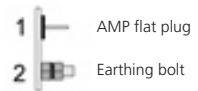

Circuit example

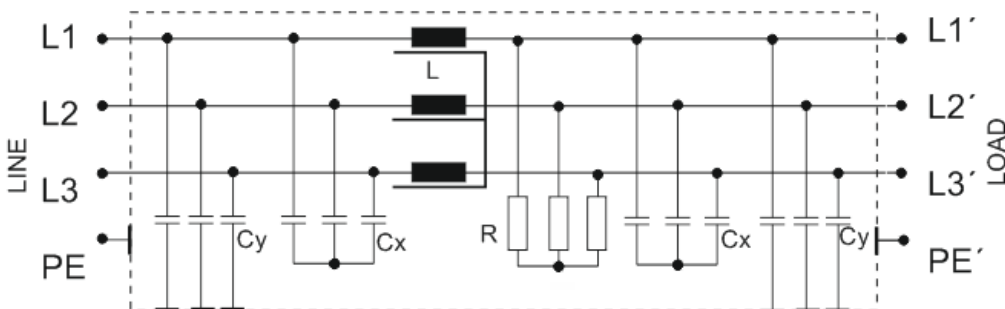

# CNW 107.3

High current mains filter, three wire

CNW 107.3

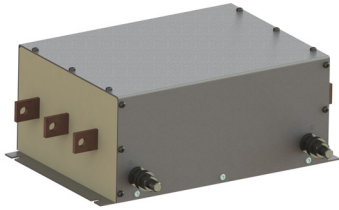

## Advantages

- Specifically designed for high performances
- Suitable for offshore applications
- Compact design
- Good heat dissipation
- Rail connector
- Fast installation

## Technical data

CNW 107.3						
Type	Rated voltage [V]	Rated current [A]	Leakage current [mA]	L [μH]	ΣCx [μF]	ΣCy [μF]
CNW 107.3/280	3 x 480 / 690	3x280	<300	100	40	3,8
CNW 107.3/500		3x500	<300	100	40	3,8
CNW 107.3/700		3x700	<300	100	40	3,8
CNW 107.3/1000		3x1000	<300	100	40	3,8
CNW 107.3/1600		3x1600	<300	44	50	3,8
CNW 107.3/2500		3x2500	<300	44	50	3,8
CNW 107.3/3000		3x3000	<300	40	50	3,8



Typical applications: Suppression of frequency inverters, power electronics and general suppression for higher power ratings on wind energy and industrial applications.

# Dimensions in mm

CNW 107.3									
Type	Connection	PE-Connection	Dimensions [mm]						
			L 1	L 2	L 3	L 4	B 1	B 2	H 1
CNW 107.3/280	30x5	M12	420	335	320	296	220	175	135
CNW 107.3/500	40x5	M12	420	335	320	296	220	175	135
CNW 107.3/700	40x10	M12	420	335	320	296	220	175	135
CNW 107.3/1000	40x10	M12	420	335	320	296	220	175	135
CNW 107.3/1600	50x10	M12	590	406	340	360	330	300	180
CNW 107.3/2500	80x15	M12	590	406	340	360	330	300	180
CNW 107.3/3000	120x15	M12	700	506	400	420	390	360	240

Attenuation curve CNW107.3

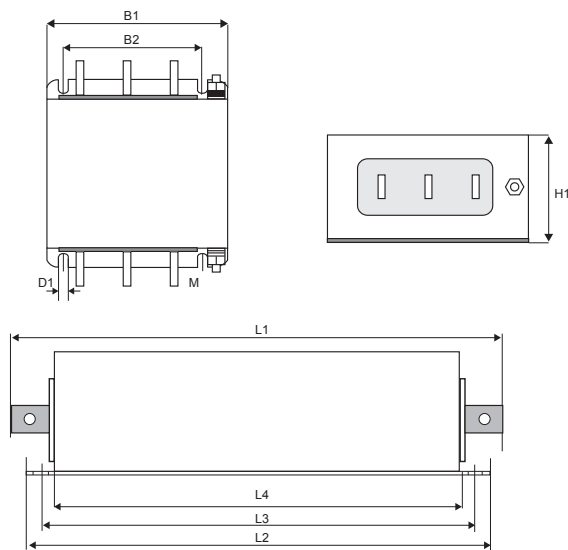
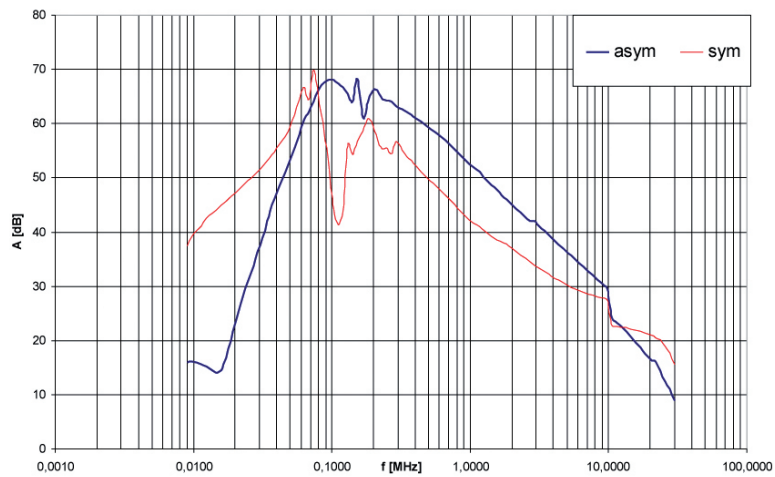

# N CNW 114

Three phase mains filter, single-stage, three wire

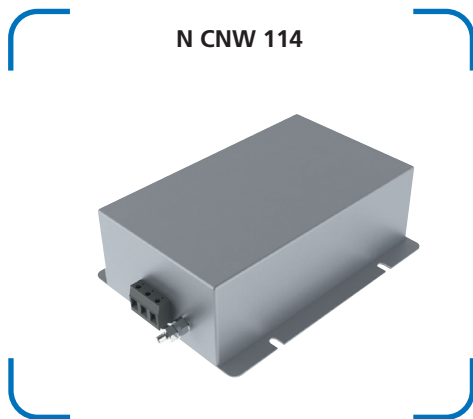

## Advantages

- Small dimensions
- Quick connection
- Low temperature rise
- Touch-proof terminals
- Very good attenuation in a wide frequency spectrum
- IT-versions possible
- UL approval for CNW

## Technical data

N CNW 114								
Type	Rated voltage [V]	Rated current [A]	Leakage current [mA]	Cx [μF]	Cy [μF]	L [mH]	R [MΩ]	Frequency [Hz]
CNW 114/8	3 x 500	8	<5	1,0	0,244	7,6	1,12	50/60
CNW 114/16		16	<30	2,53	1,57	5,2	1,12	
CNW 114/25		25	<30	2,53	1,57	2,5	1,12	
CNW 114/36		36	<30	2,53	1,57	1,5	1,12	
CNW 114/50		50	<30	2,53	1,57	0,9	1,12	
CNW 114/64		64	<30	2,53	1,57	0,9	1,12	
CNW 114/80		80	<35	3,63	1,68	0,8	1,12	
CNW 114/110		110	<35	3,63	1,68	0,5	1,12	
CNW 114/180		180	<35	3,63	1,68	0,5	1,12	
CNW 114/300		300	<60	7,26	3,36	0,3	1,12	
CNW 114/450		450	<60	7,26	3,36	0,16	1,12	
CNW 114/600		600	<60	7,26	3,36	0,155	1,12	
CNW 114/900		900	<60	7,26	3,36	0,055	1,12	
CNW 114/1200	1200	<60	7,26	3,36	0,055	1,12		



Typical applications: Frequency converters for motor drives, wind power installations and power supply units

# Dimensions in mm

N CNW 114												
Type	Housing	Connection	PE-Connection	Dimensions								
				B1 [mm]	B2 [mm]	B3 [mm]	D1 [mm]	D2 [mm]	H [mm]	L1 [mm]	L2 [mm]	L3 [mm]
CNW 114/8	B	Clamps 4mm <sup>2</sup>	2 x M6	98	80	70	5	-	70	177	150	90
CNW 114/16	B	Clamps 4mm <sup>2</sup>	2 x M6	148	135	120	7	-	70	227	200	160
CNW 114/25	B	Clamps 6mm <sup>2</sup>	2 x M6	148	135	120	7	-	70	229	200	160
CNW 114/36	B	Clamps 10mm <sup>2</sup>	2 x M6	148	135	120	7	-	70	229	200	160
CNW 114/50	B	Clamps 16mm <sup>2</sup>	2 x M6	148	135	120	7	-	70	238	200	160
CNW 114/64	B	Clamps 16mm <sup>2</sup>	2 x M6	148	135	120	7	-	70	238	200	160
CNW 114/80	B	Clamps 25mm <sup>2</sup>	2 x M10	168	155	140	7	-	90	303	240	160
CNW 114/110	B	Clamps 50mm <sup>2</sup>	2 x M12	168	155	140	7	-	90	331	240	160
CNW 114/180	B	Clamps 95mm <sup>2</sup>	2 x M12	168	155	140	7	-	90	339	240	160
CNW 114/300	C	Connection bolt (M12)	1 x M10	265	250	230	7	-	130	438	348	180
CNW 114/450	D	Copper bar (25 x 8)	1 x M12	265	240	215	9	10,5	160	530	440	190
CNW 114/600	D	Copper bar (30 x 10)	1 x M12	265	240	215	9	10,5	160	550	440	190
CNW 114/900	D	Copper bar (50 x 10)	1 x M12	265	240	215	9	14	160	630	440	190
CNW 114/1200	D	Copper bar (60 x 10)	1 x M12	265	240	215	9	14	160	630	440	190

Housing B

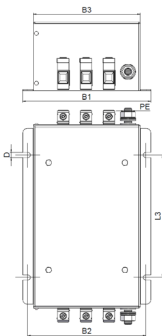

Housing C

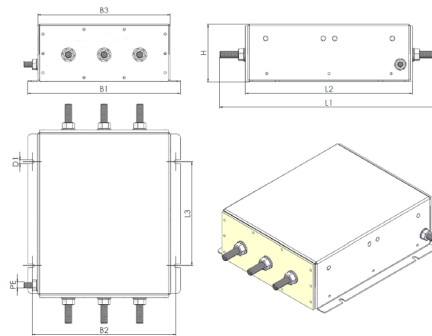

Housing D

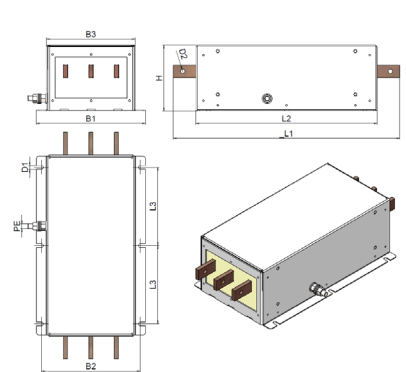

Connections

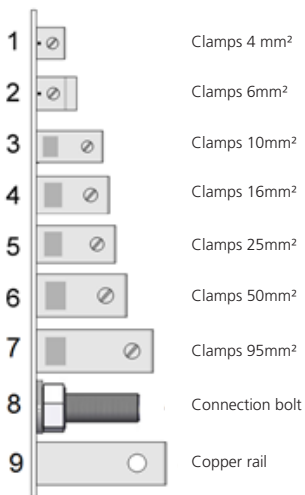

Circuit example

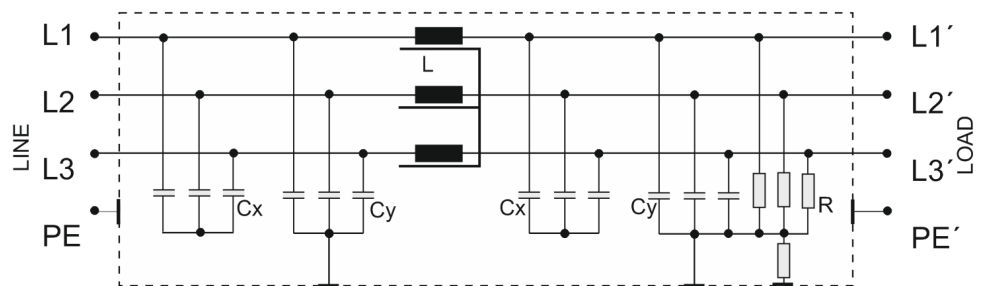

PE-Connections



# N CNW 105

Three phase mains filter, single-stage, four wire

N CNW 105

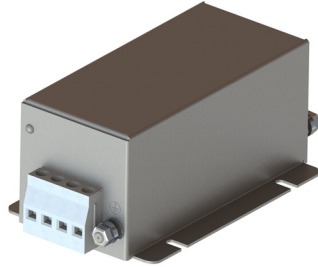

## Advantages

- Small dimensions
- Quick connection
- Low temperature rise
- Touch-proof terminals
- Good damping performance at a low leakage current

## Technical data

N CNW 105								
Type	Rated voltage [V]	Rated current [A]	Leakage current [mA]	Cx [μF]	Cy [nF]	L [mH]	R [kOhm]	Frequency [Hz]
CNW 105/3	3x500	4x3	<1	0,5	30	4,0	1,12	50/60
CNW 105/6		4x6		0,5		2,4		
CNW 105/10		4x10		0,5		1,0		
N CNW 105/16		4x16		1	43	1,6		
N CNW 105/25		4x25		1		1,4		
N CNW 105/36		4x36		2,2	44	1,2		
N CNW 105/50		4x50	2,2	0,75				
N CNW 105/80		4x80	3,3	111	0,5			
N CNW 105/120		4x120	<3,5		3,3	0,36		
N CNW 105/150		4x150	3,3					



Typical applications: Power supply units for data systems engineering, telecommunications, medical equipment and industrial applications

# Dimensions in mm

N CNW 105											
Type	Casing	Connection	PE-Connection	Dimensions [mm]							
				B1 [mm]	B2 [mm]	B3 [mm]	D [mm]	H [mm]	L 1 [mm]	L 2 [mm]	L 3 [mm]
CNW 105/3	A	AMP flat plug 6,3 mm	Flat plug flag	53	-	-	5,3	40	110	100	90
CNW 105/6	A			53	-	-	5,3	40	110	100	90
CNW 105/10	A			53	-	-	5,3	40	110	100	90
N CNW 105/16	B	Clamps 4mm <sup>2</sup>	Earthing bolt (M6)	98	80	70	5,0	70	177	150	90
N CNW 105/25	B	Clamps 6mm <sup>2</sup>		98	80	70	5,0	70	179	150	90
N CNW 105/36	B	Clamps 10mm <sup>2</sup>		148	135	120	7,0	70	269	240	160
N CNW 105/50	B	Clamps 25mm <sup>2</sup>		148	135	120	7,0	70	278	240	160
N CNW 105/80	B		Earthing bolt (M10)	168	155	140	7,0	90	303	240	160
N CNW 105/120	B	Clamps 50mm <sup>2</sup>	Earthing bolt (M12)	168	155	140	7,0	90	331	240	160
N CNW 105/150	B			168	155	140	7,0	90	331	240	160

Housing A

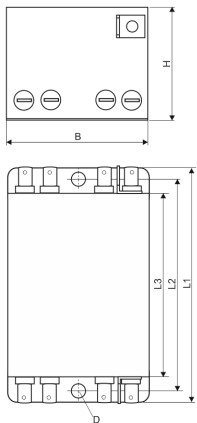

Housing B

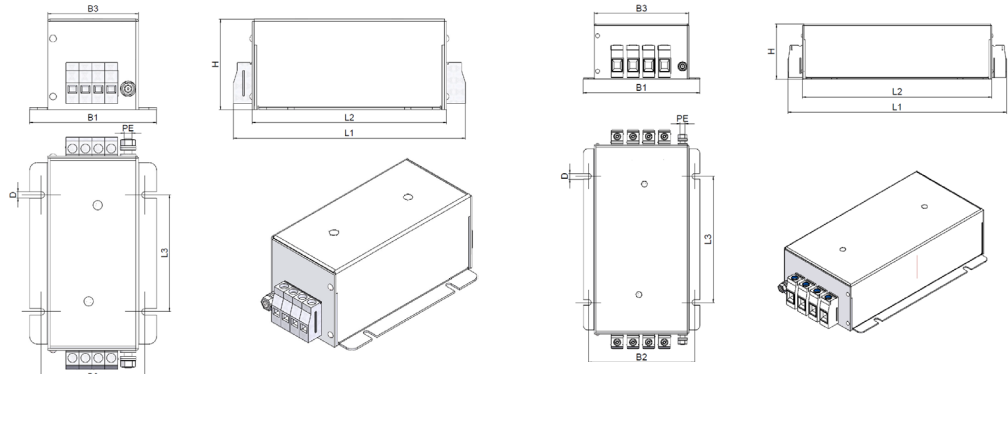

Connections

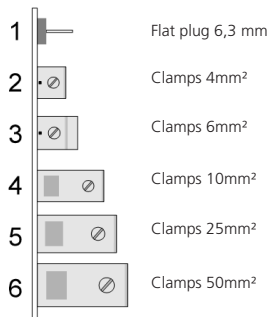

Circuit example

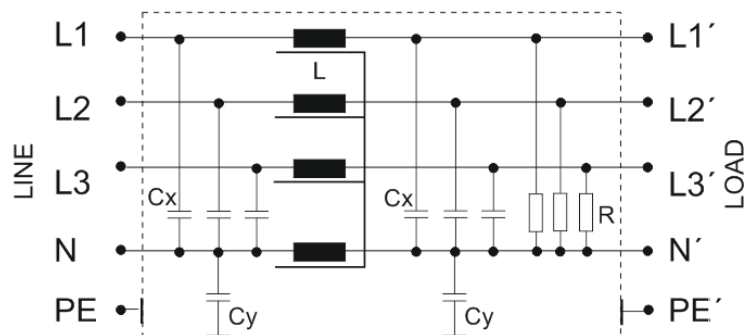

PE-Connections

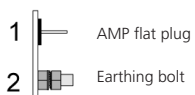





**REO**

# Braking resistors

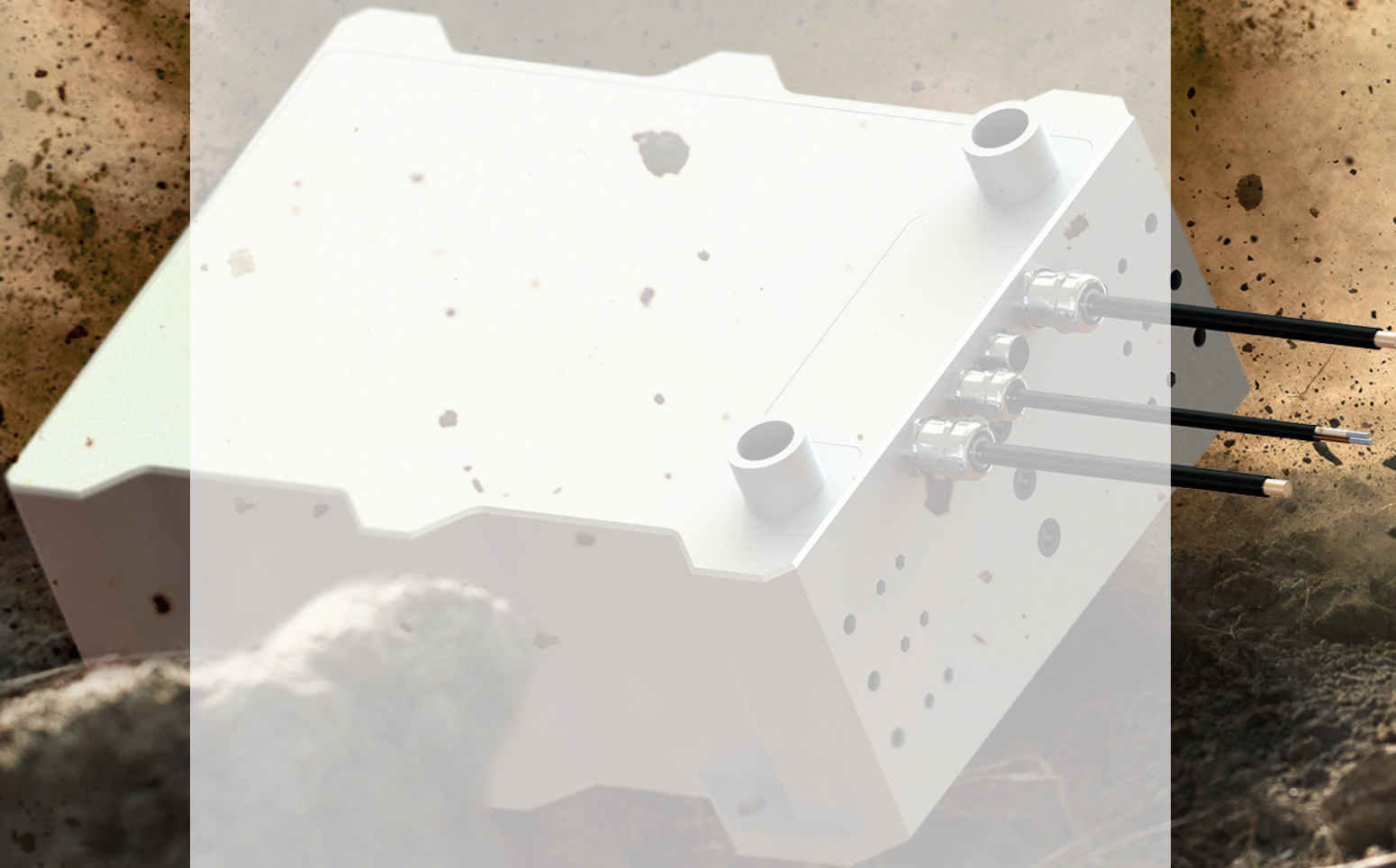

# Braking resistors

Useful facts about REOhm resistors	P. 67-69
REOhm Series BW 15X	P. 70-71
Compact Braking resistor BW 151	P. 72-73
Compact Braking resistor BW 154	P. 74-75
Compact Braking resistor BW 155	P. 76-78
Compact Braking resistor BW 155 - combination	P. 79-81
Compact Braking resistor BW 156	P. 82-84
Compact Braking resistor BW D 330	P. 86-87
Compact Braking resistor BWD 158	P. 88-89

## Useful facts about REOhm resistor

If installed on a non or poor heat-conducting material, the performance must be checked due to the reduced heat dissipation. When mounting vertically, it is essential to ensure that the connections or terminals are located on the underside of the resistor. An installation which has the connections on the uppermost side is not allowed! If several resistors are mounted one above the other, mutual interference must be taken into account. Here the compliance with the above mentioned ambient conditions must be observed and the

installation conditions checked on site. When mounted directly on a heat sink or cooling surface, the continuous power of the resistor can be increased or the surface temperature reduced. Depending on the type and size of the cooling surface / heat sink, the output can be increased by a factor of 1.5 - 4. However, this must be checked in individual cases, whereby the specified ambient conditions still apply.

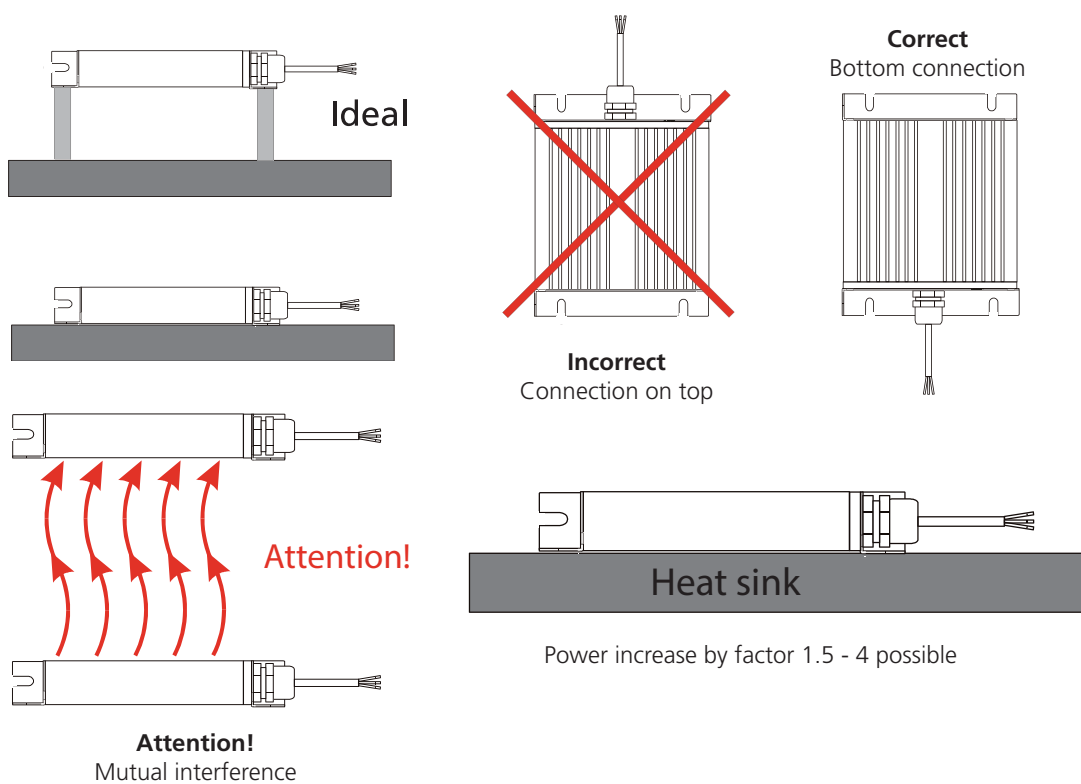

## Useful facts about REOhm resistors

### Calculation of continuous power

If the kinetic energy  $E_{kin}$  emitted to the braking resistor during braking is known, the continuous power can be determined directly from the amount of energy and the cycle time.

$$P = E_{kin} / SD$$

$P$  = Continuous power  
 $E_{kin}$  = Kinetic energy  
 $SD$  = Cycle time

If the kinetic energy is not known, the duty cycle  $ED$  and the cycle time  $SD$  are required.

$$ED[\%] = \frac{ED[s]}{SD[s]} \cdot 100$$

$ED$  = Duty cycle  
 $SD$  = Cycle time

The continuous power for a duty cycle of 10% can be calculated as follows:

$$P = P_{max} \times 10\%$$

At a duty cycle of 50% the result is:

$$P = P_{max} \times 50\%$$

The continuous power ( $P$ ) is therefore smaller than the maximum pulse power ( $P_{max}$ ) by a corresponding factor. The calculations at REO refer to intermittent braking at a cycle time of 120 seconds.

Due to their special wound construction and heat conductive insulating material, REOhm braking resistors ensure that the heat can be quickly transported to the surface during pauses, which allows the heat to dissipate over a longer period of time. However, due to the rapid cooling of the winding, pulses can always be absorbed without compromising safety or the resistors performance. The REOhm braking resistors of the standard series are designed for a duty cycle of 5% -100%. Smaller duty cycles are also possible on request.

Load diagram for air-cooled resistors

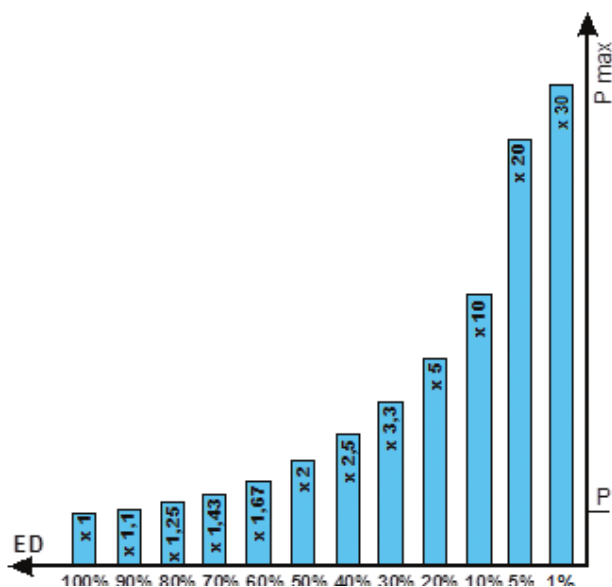

$SD$  = Cycle time max. 120 sec  
 $ED$  = Duty cycle

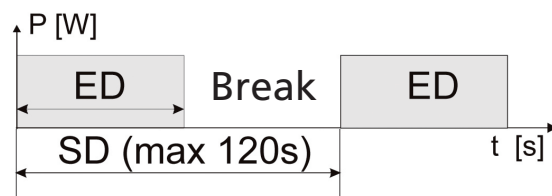

## Standards

Standards	
Standard	Description
<b>EN 60204.1</b> <b>VDE 0113</b>	EN 60204-1 with the title safety of machinery - Electrical equipment of machines - part 1: General requirements regulate general specifications and recommendations for the safety, functionality and maintenance of the electrical equipment of machines.
<b>EN 60664-1</b> <b>VDE 0110</b>	Insulation coordination for electrical equipment in low-voltage systems - Part 1: Principles, requirements and tests German version EN 60664-1
<b>DIN 17471</b>	Resistor materials; properties
<b>EN 60529</b>	These are specified in DIN EN 60529 with the title Protection classes by enclosures (IP code). With regard to their suitability for different environmental conditions, the systems are divided into corresponding degrees of protection, so called IP codes. According to DIN, the abbreviation IP stands for International Protection, but is used in the English-speaking world as Ingress Protection.
<b>EN 50124-1</b> <b>VDE 0115</b>	Insulation Coordination - Railway Applications Part 1: Basic requirements Creepage distances and clearances for all electrical and electronic equipment German version EN 50124-1
<b>EN 50155</b> <b>VDE 0115</b>	Railway applications - Electronic equipment on rail vehicles; German version EN 50155
<b>UL 94</b>	Flammability according to UL 94

## REOhm Series BW 15X

In industry, the resistors have to work safely for many years under difficult environmental conditions. In addition to the permissible temperature range, the environmental conditions i.e. resistance to common railway pollutants such as vapours, gases, coal dust, oil or brake abrasion, represents a restriction of use. In addition, the penetration of moisture and foreign bodies, such as dust, must be prevented for reliable operation.

### Advantages

The REOhm resistors of the BW 15X series are characterized by high functional reliability and a long service life. Due to their special design, REOhm resistors offer very high mechanical protection and are not susceptible to vibrations and oscillations. Due to this design, the resistor can absorb higher pulse loads and dissipate them effectively. External environmental influences have very little effect on the resistor, i.e. they are less sensitive to moisture and dirt. Profile resistors emit low levels of audible noise.

### Resistor value / temperature dependence

The resistor value changes slightly depending on the winding temperature. This results in resistor changes of approx. +10% compared to the cooled state.

The performance data in the data sheets apply under the following operating conditions:

- Maximum ambient temperature 40 °C
- Unimpeded air flow to ensure cooling
- If the ambient temperature is higher than 40 °C, the continuous power must be reduced by 5% per 10K temperature increase.

The resistors are short-circuit proof and self-extinguishing. (All series except REOhm R)

The resistors are designed to convert electrical energy into heat, so heating of the vicinity and adjacent housing parts is unavoidable. It must be ensured that the cooling air flows in and out freely and that sufficient heat is dissipated via cooling surfaces.

### Protection classes

Depending on the design and construction, different degrees of protection can be provided. For protection class  $\leq$  IP20 the temperature increase at the hottest point of the resistor surface must not exceed 300K. For a higher degree of protection ( $>$  IP20), a maximum temperature increase of 200K applies at the hottest point of the resistor surface.

### Overheating Protection

It is possible to monitor the temperature of the resistor with a temperature switch. When a nominal temperature is exceeded, the temperature switch opens and triggers a signalling contact. The temperature switch is equipped with two cables ready for connection.

# Operating conditions

REOhm Series BW 15X	
<b>Ambient temperature</b>	-15 °C ... +70 °C Operating, storage and transport temperature Over 40°C Reduce continuous power Pd by 5% 10K  Max. relative humidity 5-85% non-condensing during operation
<b>Installation altitude</b>	0 ... 4000 m üNN over 1000 m Reduce continuous power Pd by 5% / 1000 m
<b>Installation place</b>	The installation site must correspond to the device characteristics specified in the „General data“. Flammable materials or substances must not be in the vicinity of the braking resistor. The heat generated by the braking resistor must be dissipated unhindered.
<b>Mounting position</b>	Vertically suspended with connections at the bottom or horizontal mounting
<b>Installation clearances</b>	Top > 200 mm Below > 100 mm Lateral > 25 mm

# General data

REOhm Series BW 15X	
<b>Conformity</b>	CE low voltage directional
<b>Temperature switches</b>	Normally closed version, 200 °C
<b>Switching capacity</b>	250 V AC / 0,5A
Insulation resistance > 5 MΩ / bei 1000 V	

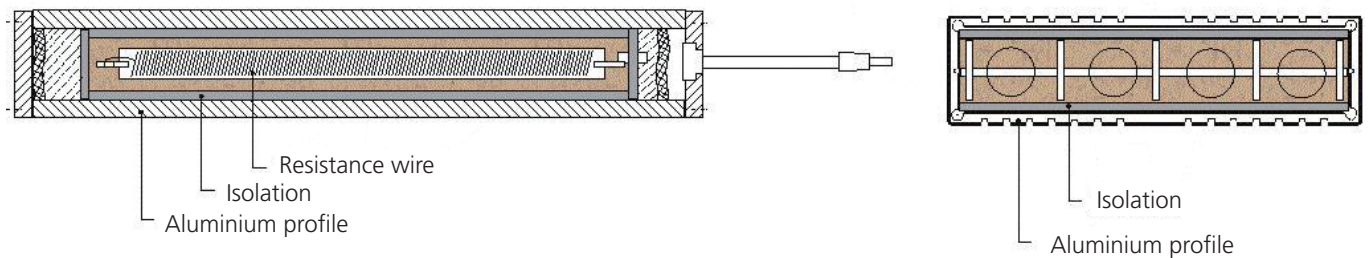

## Compact Braking resistor

### BW 151

BW 151/100 - 300 W

#### Advantages:

- Easily combined
- Intrinsically safe
- Very flat and compact design with open grooves for vertical mounting
- Adaptation to any frequency inverter
- Very good heat dissipation, mounting on heat sink possible
- High resistance at overload
- Quick connection
- Also with UL certification
- Options available with temperature switches

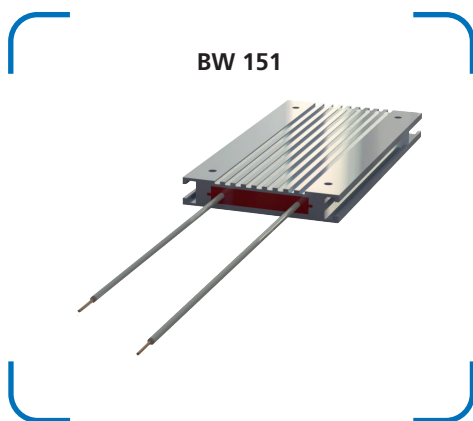

#### Technical data

BW 151			
Type	Resistance R [Ohm]	Continuous output [ W ]	max. operating voltage U [ V ]
BW 151 / 100	3 - 300	100	900
BW 151 / 150	4 - 300	150	
BW 151 / 200	5 - 1000	200	
BW 151 / 250	5 - 1000	250	
BW 151 / 300	7 - 2000	300	



Typical applications: Braking resistor for drives with frequency converters of low to medium power or as a charging resistor.

Mounting close to the frequency inverter.

Performances: Protection class IP54, test voltage 2,5 kV AC, other capacities and mounting dimensions on request



# Dimensions in mm

BW 151								
Type	Dimensions							Connections
	B1 [mm]	B2 [mm]	H1 [mm]	L1 [mm]	L2 [mm]	L3 [mm]	D [mm]	
BW 151 / 100 / ...	80	60	14	110	80	250	4,2	2 x AWG 14/18, UL 1659
BW 151 / 150 / ...				160	130			
BW 151 / 200 / ...				210	180			
BW 151 / 250 / ...				260	230			
BW 151 / 300 / ...				310	280			

In the event of failure, the resistor becomes high-impedance. Each series is available with a temperature switch. The specified performance values were measured at a horizontal position of the resistors in the air with a distance of min. 100mm to the substrate. The power values refer to the standard products with a normal tolerance of +/- 10% at an ambient temperature of 20°C.

We are also happy to produce customer-specific solutions outside our standard portfolio - just contact us!

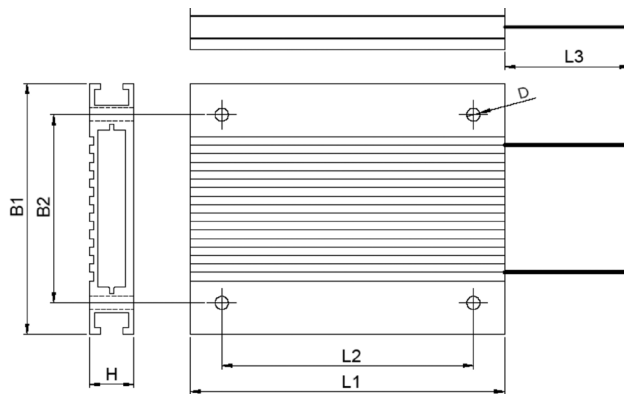
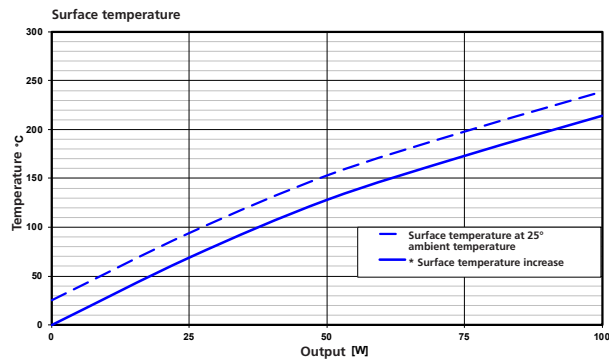

## Compact Braking resistor

### BW 154

BW 154/100 - 250 W

### Advantages

- Small dimensions at high output
- Fast connection
- Intrinsically safe
- Adaptation to any frequency inverter
- High power to size ratio
- Compact design
- High resistance at overload
- Vertical and horizontal construction
- Options available with temperature switches



### Technical data

BW 154				
Type	Resistance R [Ohm]	Continuous output at 25°C and surface over temperature of P [ W ]		max. operating voltage U [ V ]
		200 K	250 K	
BW 154 / 100	3 - 500	100	150	900
BW 154 / 150	2,2 - 160	120	160	
BW 154 / 200	5 - 200	140	180	
BW 154 / 250	5 - 250	160	200	

Typical applications: Braking resistor for drives with frequency converters of low to medium power or as a charging resistor. Mounting close to the frequency inverter.

Performances: Protection class IP 54, higher protection classes on request, test voltage 2,5 kV AC other capacities and mounting dimensions on request

# Dimensions in mm

BW 154								
Type	B1 [mm]	H1 [mm]	L1 [mm]	L2 [mm]	L3 [mm]	L4 [mm]	D [mm]	Connection cable
BW 154 / 100	40	21	170	155	140	250	5,5	2 x AWG 14,UL 1659
BW 154 / 150	40	21	210	195	180	250	5,5	2 x AWG 14,UL 1659
BW 154 / 200	40	21	250	235	220	250	5,5	2 x AWG 14,UL 1659
BW 154 / 250	40	21	290	275	260	250	5,5	2 x AWG 14,UL 1659

In the event of destruction, the resistor becomes high-impedance. Each series is available with a temperature switch. The specified performance values were measured at a horizontal position of the resistors in the air with a distance of min. 100mm to the substrate. The power values refer to the standard products with a normal tolerance of +/- 10% at an ambient temperature of 20°C.

We are also happy to produce customer-specific solutions outside our standard portfolio - just contact us!

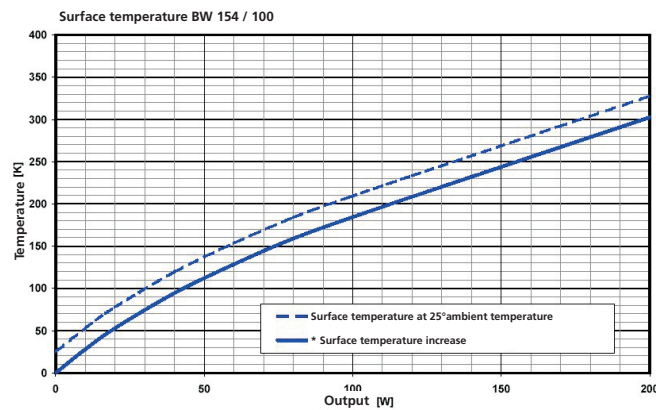

Horizontal view

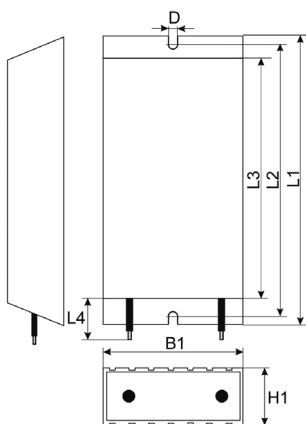

Standing view

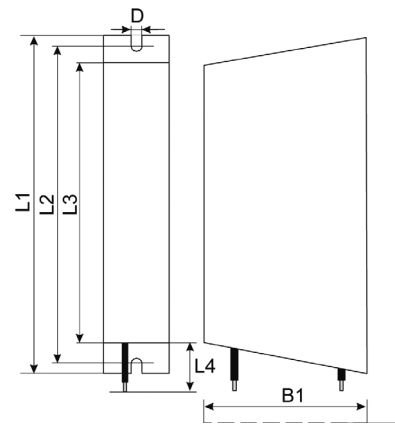

# Compact Braking resistor

## BW 155

BW 155/1000 - 3500 W

### Advantages

- Protection class IP20 / IP65 / IP66
- Small dimensions at high output
- Fast connection
- Short-circuit proof
- Very good heat dissipation
- High-resistance at overload
- Options available with terminal covers and temperature switches
- Installation also possible outside the control cabinet

Compact Braking resistor BW 155

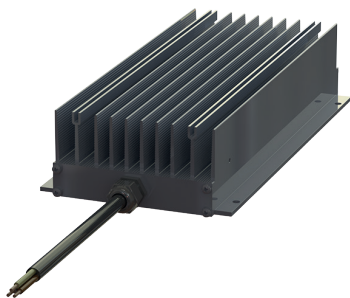

**Certified for railway technology**

### Technical data

Compact Braking resistor BW 155				
Type	Resistance R [Ohm]	Continuous output P [W] IP20	Continuous output P [W] IP65, IP66	max. operating voltage U [V]
BW 155 / 1000 / IP..	1 - 1000	1000	600	900
BW 155 / 1200 / IP..	1,2 - 300	1200	800	
BW 155 / 1500 / IP..	1,5 - 280	1500	1000	
BW 155 / 2000 / IP..	2 - 1440	2000	1500	
BW 155 / 2500 / IP..	2,5 - 600	2500	1875	
BW 155 / 3000 / IP..	3 - 750	3000	2250	
BW 155 / 3500 / IP..	4 - 750	3500	2500	

In the event of destruction, the resistor becomes high-impedance. Each series is available with a temperature switch. The specified performance values were measured at a horizontal position of the resistors in the air with a distance of min. 100mm to the substrate. The power values refer to the standard products with a normal tolerance of +/- 10% at an ambient temperature of 20°C.

\*Other resistance values on request.

We are also happy to produce customer-specific solutions outside our standard portfolio - just contact us!

## Mechanical data

Compact Braking resistor BW 155								
Type	Dimensions							Connection*
	B1 [mm]	B2 [mm]	H [mm]	L1 [mm]	L2 [mm]	L3 [mm]	D [mm]	
BW 155 / 1000 / IP...	175	165	75	182	120	250	6,5	IP20 PTFE AWG14
BW 155 / 1200 / IP...	175	165	75	242	180	250	6,5	
BW 155 / 1500 / IP...	175	165	75	342	280	250	6,5	
BW 155 / 2000 / IP...	175	165	75	542	500	250	6,5	
BW 155 / 2500 / IP...	175	165	75	672	630	250	6,5	
BW 155 / 3000 / IP...	175	165	75	762	720	250	6,5	
BW 155 / 3500 / IP...	175	165	75	872	830	250	6,5	

Compact Braking resistor BW 155								
Type	Dimensions							Connection*
	B1 [mm]	B2 [mm]	H [mm]	L1 [mm]	L2 [mm]	L3 [mm]	D [mm]	
BW 155 / 1000 / IP...	175	165	75	182	120	1000	6,5	IP65 (IP66) shielded connection cable 3x1,5 mm <sup>2</sup> oder 3x2,5 mm <sup>2</sup>
BW 155 / 1200 / IP...	175	165	75	242	180	1000	6,5	
BW 155 / 1500 / IP...	175	165	75	342	280	1000	6,5	
BW 155 / 2000 / IP...	175	165	75	542	500	1000	6,5	
BW 155 / 2500 / IP...	175	165	75	672	630	1000	6,5	
BW 155 / 3000 / IP...	175	165	75	762	720	1000	6,5	
BW 155 / 3500 / IP...	175	165	75	872	830	1000	6,5	

Typical applications: For drives with frequency converters of small to medium output, installation close to the frequency converter: Test voltage: 2,5 kV DC

## Technical Data Contact protection / cover

Compact Braking resistor BW 155						
Type	Dimensions					
	L1 [mm]	L2 [mm]	B1 [mm]	B2 [mm]	H [mm]	D [mm]
BW 155 / 1000 / ...	470	440	275	225	200	7,0x10,0
BW 155 / 1200 / ...	530	500	275	225	200	7,0x10,0
BW 155 / 1500 / ...	630	600	275	225	200	7,0x10,0
BW 155 / 2000 / ...	830	800	275	225	200	7,0x10,0
BW 155 / 2500 / ...	960	930	275	225	200	7,0x10,0
BW 155 / 3000 / ...	1050	1020	275	225	200	7,0x10,0
BW 155 / 3000 / ...	1160	1130	275	225	200	7,0x10,0

Other covers are available on request.

\* For low resistance values, the conductor cross-section is adapted to the current.

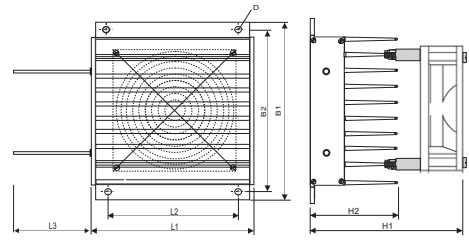
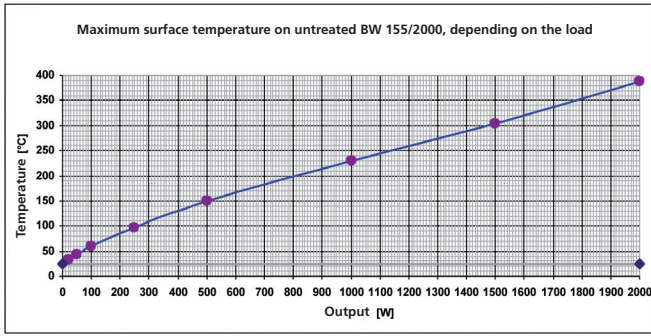

Design IP 20

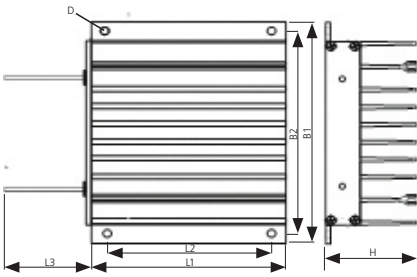

Design IP65

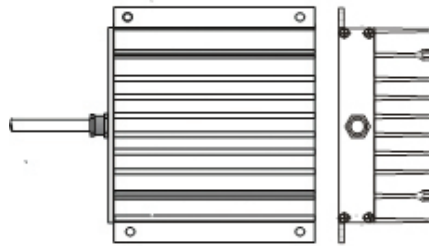

Design IP65 / TS

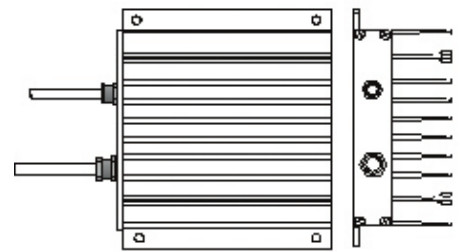

Dimension drawing  
Contact protection / cover

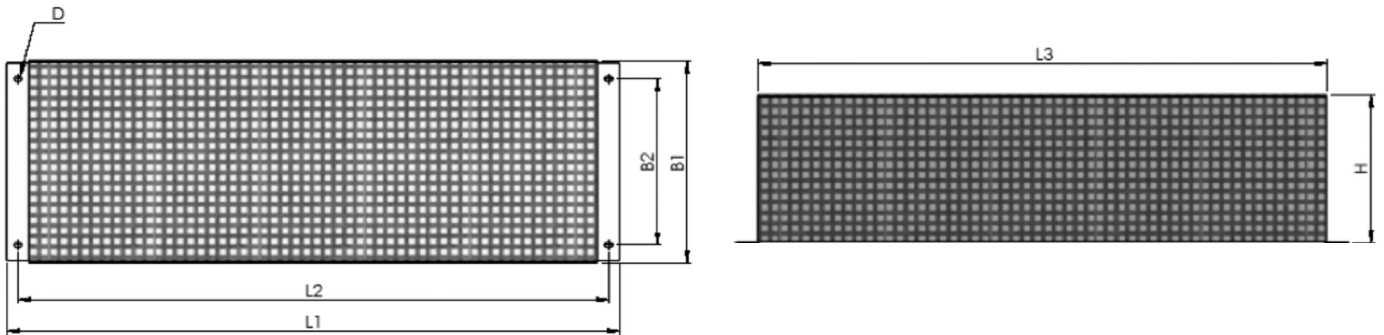

# Compact Braking resistor BW 155 - Combination

BW 155/4.000 - 30.0000 W

## Advantages

- Protection class IP20 / IP65 / IP66
- Small dimensions at high output
- Fast connection
- Short-circuit proof
- Very good heat dissipation
- High-resistance at overload
- Options available with terminal covers and temperature switches
- Installation also possible outside the control cabinet

Compact Braking resistor BW 155-  
combination

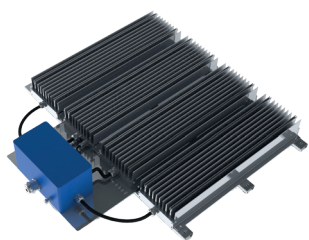

## Technical data

Compact Braking resistor BW 155 - combination				
Type	Resistance R [Ohm] to the E12 series*	Continuous output P [W] IP20	Continuous output P [W] IP65, IP66	max. operating voltage U [V]
BW 155 / 4000 / IP...	1 - 180	4000	3000	900
BW 155 / 5000 / IP...	1 - 150	5000	3750	
BW 155 / 6000 / IP...	1 - 120	6000	4500	
BW 155 / 7500 / IP...	1 - 100	7500	5600	
BW 155 / 9000 / IP...	1 - 82	9000	6750	
BW 155 / 10000 / IP...	1 - 68	10000	7500	
BW 155 / 12000 / IP...	1 - 56	12000	9000	
BW 155 / 15000 / IP...	1 - 47	15000	11250	
BW 155 / 18000 / IP...	1,5 - 39	18000	13500	
BW 155 / 22000 / IP...	1,5 - 33	22000	16800	
BW 155 / 24000 / IP...	1,8 - 33	24000	18000	
BW 155 / 27000 / IP...	2,2 - 27	27000	20250	
BW 155 / 30000 / IP...	2,2 - 27	30000	22500	

\*Other resistance values on request.

For low resistance values, the conductor cross-section is adapted to the current.

## Mechanical data

Compact Braking resistor BW 155 - combination									
Type	Dimensions						Cable gland	Connection clamp Terminal	Design
	L1 [mm]	L2 [mm]	B1 [mm]	H1 [mm]	H2 [mm]	D [mm]			
BW 155 / 4000 / IP...	750	500	420	390	95	8,5	M25	10 mm <sup>2</sup>	BF 1
BW 155 / 5000 / IP...	880	630	420	390	95	8,5	M25	10 mm <sup>2</sup>	BF 1
BW 155 / 6000 / IP...	970	720	420	390	95	8,5	M25	10 mm <sup>2</sup>	BF 1
BW 155 / 7500 / IP...	880	630	590	560	95	8,5	M25	10 mm <sup>2</sup>	BF 2
BW 155 / 9000 / IP...	970	720	590	560	95	8,5	M25	10 mm <sup>2</sup>	BF 2
BW 155 / 12000 / IP...	970	720	770	740	95	8,5	M32	16 mm <sup>2</sup>	BF 3
BW 155 / 15000 / IP...	970	720	940	910	95	8,5	M32	16 mm <sup>2</sup>	BF 4
BW 155 / 18000 / IP...	970	720	2x590	2x560	95	8,5	M32	35 mm <sup>2</sup>	2x BF2
BW 155 / 24000 / IP...	970	720	2x770	2x740	95	8,5	M32	35 mm <sup>2</sup>	2x BF3
BW 155 / 27000 / IP...	970	720	3x590	3x590	95	8,5	M32	35 mm <sup>2</sup>	2x BF2
BW 155 / 30000 / IP...	970	720	2x940	2x910	95	8,5	M32	35 mm <sup>2</sup>	2x BF4

Typical applications: Braking resistor for drives with frequency converters of high output, installation close to the frequency converter: Test voltage: 2,5 kV AC, Ambient temperature: -10...+40 °C

## Technical Data Contact protection / cover

Compact Braking resistor BW 155 - combination						
Type	Dimensions					
	L1 [mm]	L2 [mm]	B1 [mm]	B2 [mm]	H [mm]	D [mm]
BW 155 / 4000 / ...	700	620	520	500	200	7,0x10,0
BW 155 / 5000 / ...	800	720	520	500	200	7,0x10,0
BW 155 / 6000 / ...	900	820	520	500	200	7,0x10,0
BW 155 / 7500 / ...	800	720	690	670	200	7,0x10,0
BW 155 / 9000 / ...	900	820	690	670	200	7,0x10,0
BW 155 / 12000 / ...	900	820	870	850	200	7,0x10,0

Other covers are available on request.

Dimension drawing  
Contact protection / cover

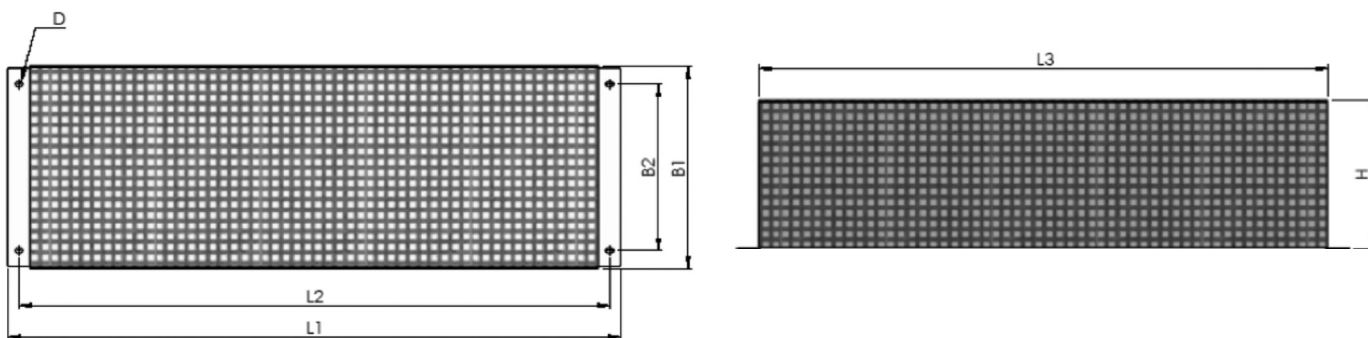



Circuit example

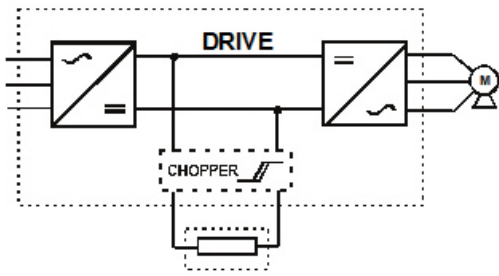

Design IP20

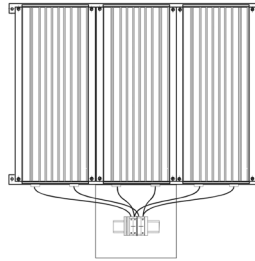

Design IP65

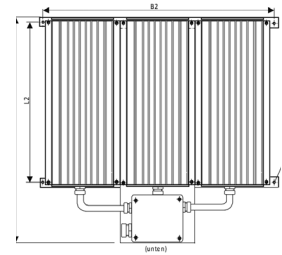

Dimension drawing, Design 1

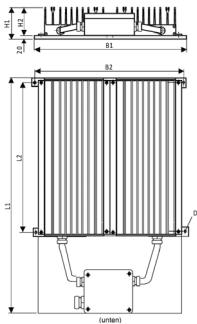

Dimension drawing, Design 2

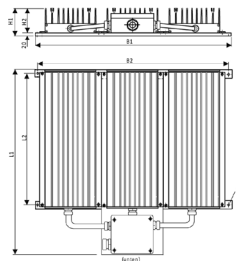

Dimension drawing, Design 3

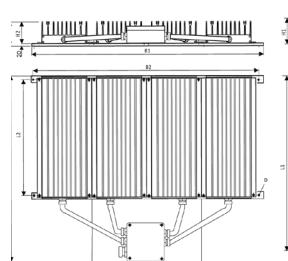

Dimension drawing, Design 4

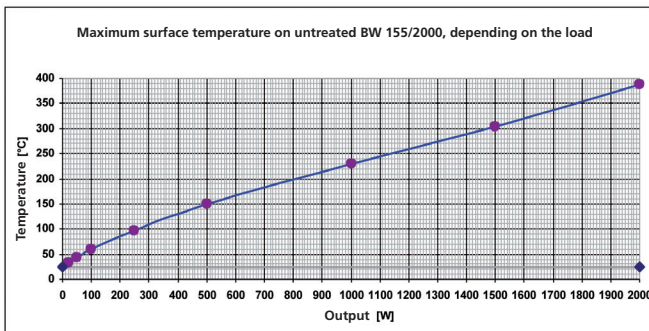
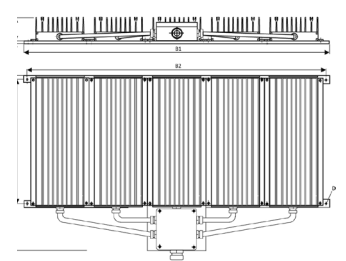

# Compact Braking resistor

## BW 156

BW 156/400 - 1500 W

### Advantages

- Protection class IP20 / IP65
- Small dimensions at high output
- Fast connection
- Short-circuit proof
- Very good heat dissipation
- High-resistance at overload
- Options available with terminal covers and temperature switches
- Installation also possible outside the control cabinet
- Also with UL certification

Compact Braking resistor BW 156

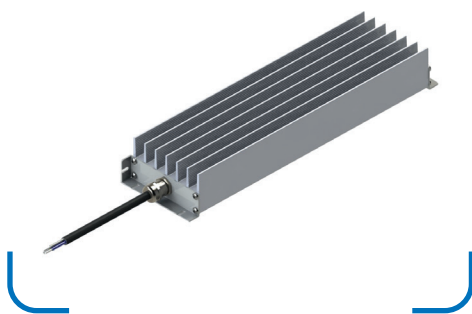

### Technical data

Compact Braking resistor BW 156				
Type	Resistance R [Ohm] to the E12 series*	Continuous output P [W] IP20	Continuous output P [W] IP65	max. operating voltage U [V]
BW 156 / 400 / IP..	1 - 820	400	300	900
BW 156 / 600 / IP..	1 - 820	600	400	
BW 156 / 800 / IP..	1,8 - 820	800	500	
BW 156 / 1000 / IP..	2,2 - 820	1000	600	
BW 156 / 1200 / IP..	2,2 - 820	1200	700	
BW 156 / 1500 / IP..	2,7 - 820	1500	800	



Typical applications: Braking resistor for drives with frequency converters of small to medium output. Installation in or outside of the control cabinet is possible: Test voltage 2,5 kV AC

In the event of destruction, the resistor becomes high-impedance. Each series is available with a temperature switch. The specified performance values were measured at a horizontal position of the resistors in the air with a distance of min. 100mm to the substrate. The power values refer to the standard products with a normal tolerance of +/- 10% at an ambient temperature of 20°C.

\*Other resistance values on request.

[We are also happy to produce customer-specific solutions outside our standard portfolio - just contact us!](#)

## Mechanical data

Compact Braking Resistors BW 156									
Type	Dimensions								Connection
	L1 [mm]	L2 [mm]	L3 [mm]	L4 [mm]	B1 [mm]	B2 [mm]	H [mm]	D [mm]	
BW 156 / 400 / IP...	170	155	140	500	104	70	53	4,5	IP20 PTFE AWG14
BW 156 / 600 / IP...	230	215	200	500	104	70	53	4,5	
BW 156 / 800 / IP...	300	285	270	500	104	70	53	4,5	
BW 156 / 1000 / IP...	370	355	340	500	104	70	53	4,5	
BW 156 / 1200 / IP...	450	435	420	500	104	70	53	4,5	
BW 156 / 1500 / IP...	600	585	570	500	104	70	53	4,5	

Compact Braking Resistors BW 156									
Type	Dimensions								Connection
	L1 [mm]	L2 [mm]	L3 [mm]	L4 [mm]	B1 [mm]	B2 [mm]	H [mm]	D [mm]	
BW 156 / 400 / IP...	174	159	140	1000	104	70	53	4,5	IP65 shielded connection cable 3x1,5 mm <sup>2</sup>
BW 156 / 600 / IP...	234	219	200	1000	104	70	53	4,5	
BW 156 / 800 / IP...	304	289	270	1000	104	70	53	4,5	
BW 156 / 1000 / IP...	374	359	340	1000	104	70	53	4,5	
BW 156 / 1200 / IP...	454	439	420	1000	104	70	53	4,5	
BW 156 / 1500 / IP...	604	589	570	1000	104	70	53	4,5	

## Technical Data Contact protection / cover

Compact Braking Resistors BW 156						
Type	Dimensions					
	L1 [mm]	L2 [mm]	B1 [mm]	B2 [mm]	H [mm]	D [mm]
BW 156 / 400 / ...	300	270	200	150	140	7,0x10,0
BW 156 / 600 / ...	360	330	200	150	140	7,0x10,0
BW 156 / 800 / ...	430	400	200	150	140	7,0x10,0
BW 156 / 1200 / ...	580	550	200	150	140	7,0x10,0
BW 156 / 1500 / ...	730	700	200	150	140	7,0x10,0

Other covers are available on request.

Circuit example

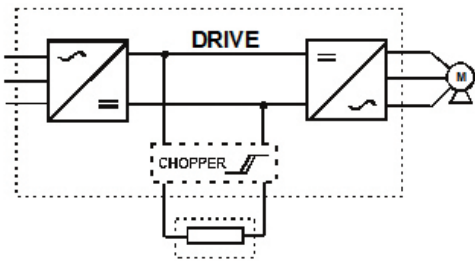

Design IP65

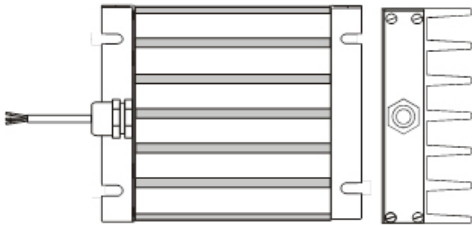

Design IP20

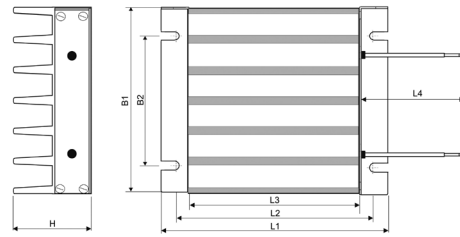

Design IP65 / TS

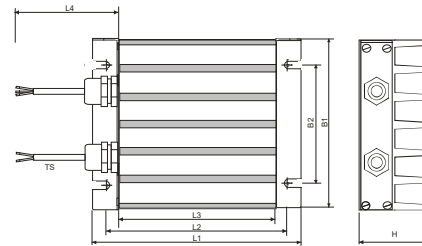

BW 156 Combination

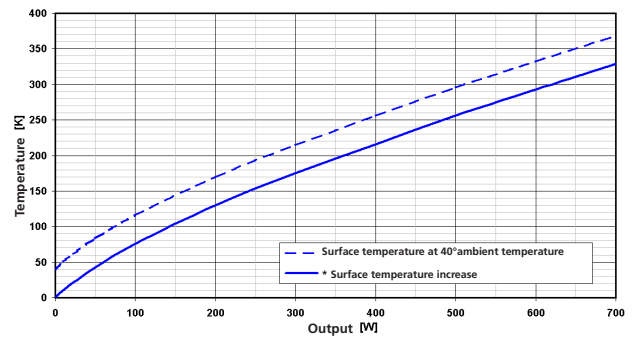
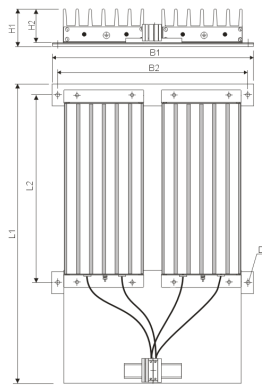

Dimension drawing  
Contact protection / cover

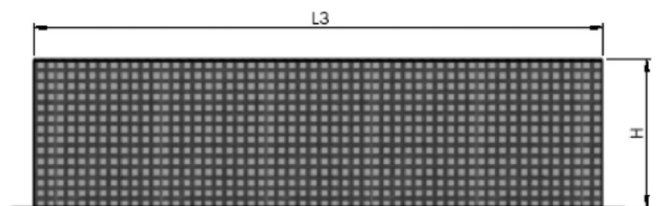
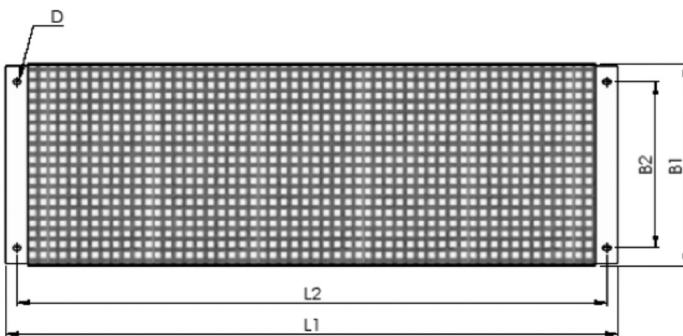

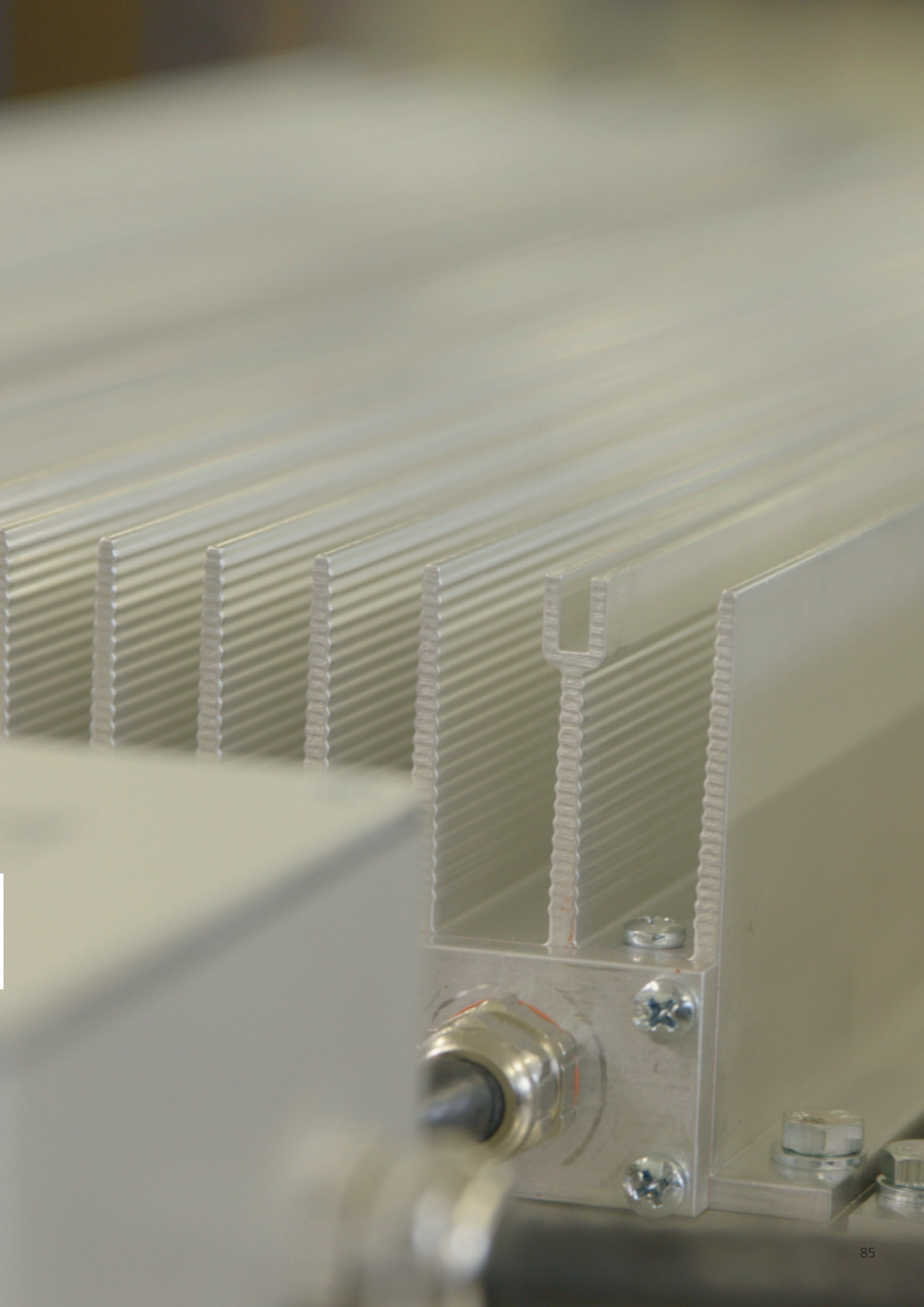

## Compact Braking resistor

### BW D 330

BW D 330/15.000 - 60.000 W

Liquid-cooled braking resistor,  
max continuous output: 60.000 W

The REO braking resistor converts excess braking energy into useful heat and is thus ideally suitable for electrical or hybrid drives. The water cooling makes an additional space saving of up to 88% possible as compared to a traditional air-cooled braking resistor. As an extra feature, the resistor can easily be connected with drip-free quick fasteners.

## Advantages

- Protection class up to IP69K
- 88% space saving
- Non-drip quick-release connectors
- Liquid Cooling
- Low weight
- Low surface temperature

Compact Braking resistor BW D 330

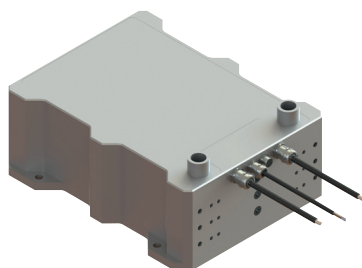

## Technical data

Compact Braking resistor BW D 330			
Type	Resistance values [Ohm]*	Continuous output [W]	Operating voltage [V]
BW D 330 / 15.000	4,2 - 43,5	15000	800
BW D 330 / 30.000	2,1 - 21,5	30000	
BW D 330 / 45.000	1,4 - 14,5	45000	
BW D 330 / 60.000	1,6 - 11	60000	

## Mechanical data

Compact Braking resistor BW D 330							
Type	Dimensions						
	L1 [mm]	L2 [mm]	B1 [mm]	B2 [mm]	D1 [mm]	D2 [mm]	H1 [mm]
D 330 / 15.000	390	250	315	285	12,5	G3/4	57
D 330 / 30.000	390	250	315	285	12,5	G3/4	87
D 330 / 45.000	390	250	315	285	12,5	G3/4	117
D 330 / 60.000	390	250	315	285	12,5	G3/4	147

Dimension drawing

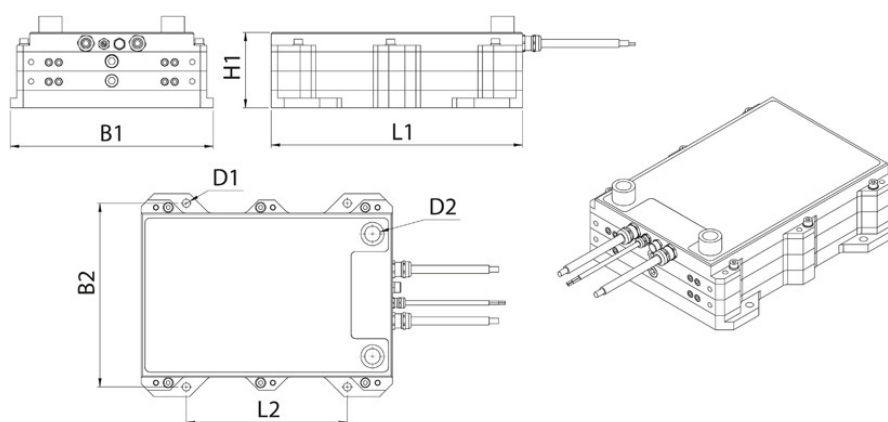

# Compact Braking resistor BWD 158

BW D 158/1000 - 60.000 W

## Advantages

- Very compact construction
- Use also possible at higher ambient temperatures
- Optimised cooling for high ratings
- Very low enclosure overtemperature (<50 °C)
- Suitable for standard cooling fluids (water/glycol)
- high protection class up to IP66
- Operating pressure of the cooling circuit up to 4 bar (test pressure 10 bar)
- Needs very little space in the control cabinet

Compact Braking resistor BWD 158

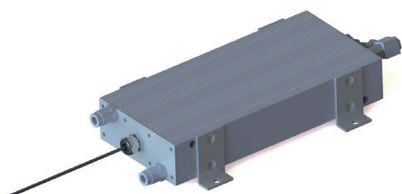

## Technical data

Compact Braking resistor BWD 158			
Type	Resistance values R [Ohm]*	Continuous output P [W]	max. operating voltage U [V]
BW D 158 / 3000	10 - 200	3.000	1000
BW D 158 / 5000	10 - 200	5.000	
BW D 158 / 6000	10 - 200	6.000	
BW D 158 / 10000	6 - 500	10.000	
BW D 158 / 15000	4 - 600	15.000	
BW D 158 / 20000	3 - 600	20.000	
BW D 158 / 30000	2,1 - 750	30.000	
BW D 158 / 45000	2,1 - 800	45.000	
BW D 158 / 60000	2 - 850	60.000	

Typical applications: For use as braking or load resistor for drive technology, industrial applications, test beds and railway engineering with integrated water cooling. Thanks to localised, optimised cooling, high outputs can be generated in the smallest space with low heat generation. It is also possible to deploy it in areas with high ambient temperatures.

\*Other resistance values on request.



# Mechanical data

Compact Braking resistor BWD 158									
Type	Dimensions						Connection		Design
	L1 [mm]	L2 [mm]	L3 [mm]	B1 [mm]	B2 [mm]	H [mm]	Cable gland	Clamp	
BW D 158 / 3000	320	213	500	190	175	68	M20	6 mm <sup>2</sup>	BF1
BW D 158 / 5000	450	343	500	190	175	68	M20	6 mm <sup>2</sup>	BF1
BW D 158 / 6000	550	443	500	190	175	68	M20	6 mm <sup>2</sup>	BF1
BW D 158 / 10000	680	343	265	176	156	170	M25	10 mm <sup>2</sup>	BF2
BW D 158 / 15000	680	343	265	245	225	170	M32	10 mm <sup>2</sup>	BF3
BW D 158 / 20000	680	343	265	2x176	2x156	170	M32	10 mm <sup>2</sup>	2xBF2
BW D 158 / 30000	680	343	265	2x245	2x225	170	M32	10 mm <sup>2</sup>	2xBF3
BW D 158 / 45000	680	343	265	3x245	3x225	170	M32	16 mm <sup>2</sup>	3xBF3
BW D 158 / 60000	680	343	265	4x245	4x225	170	M32	16 mm <sup>2</sup>	4xBF3

Circuit example

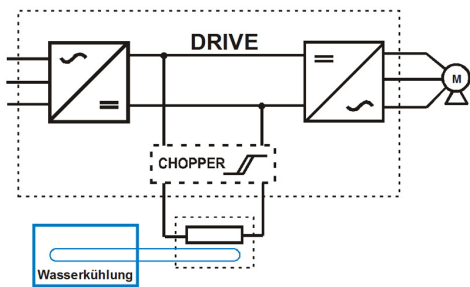

Dimension drawing, Design 1

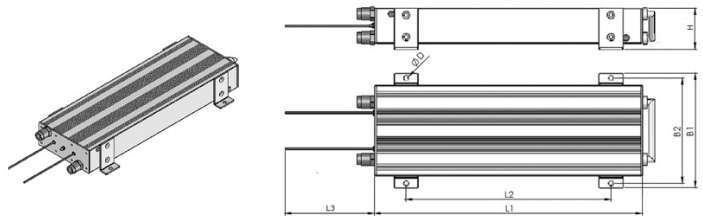

Dimension drawing, Design 2

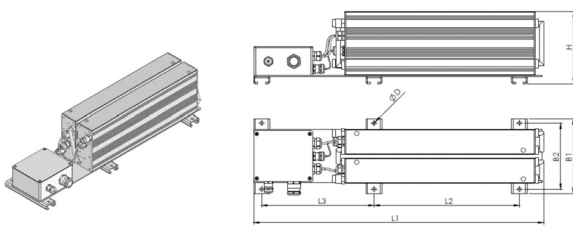

Dimension drawing, Design 3

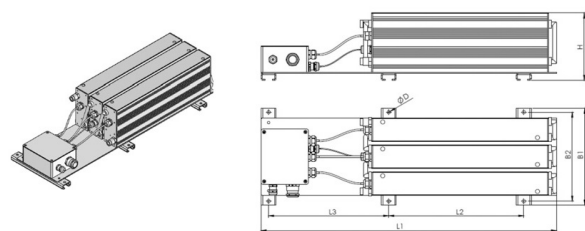

Load diagram

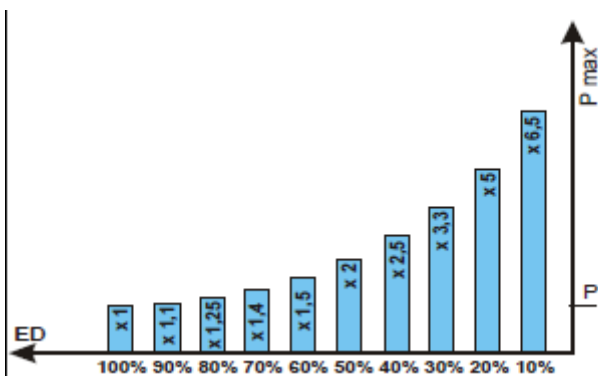



The logo for REO, consisting of the letters 'R', 'E', and 'O' in a stylized, white, outlined font, set against a solid blue rectangular background.

REO

## Current and voltage sensors

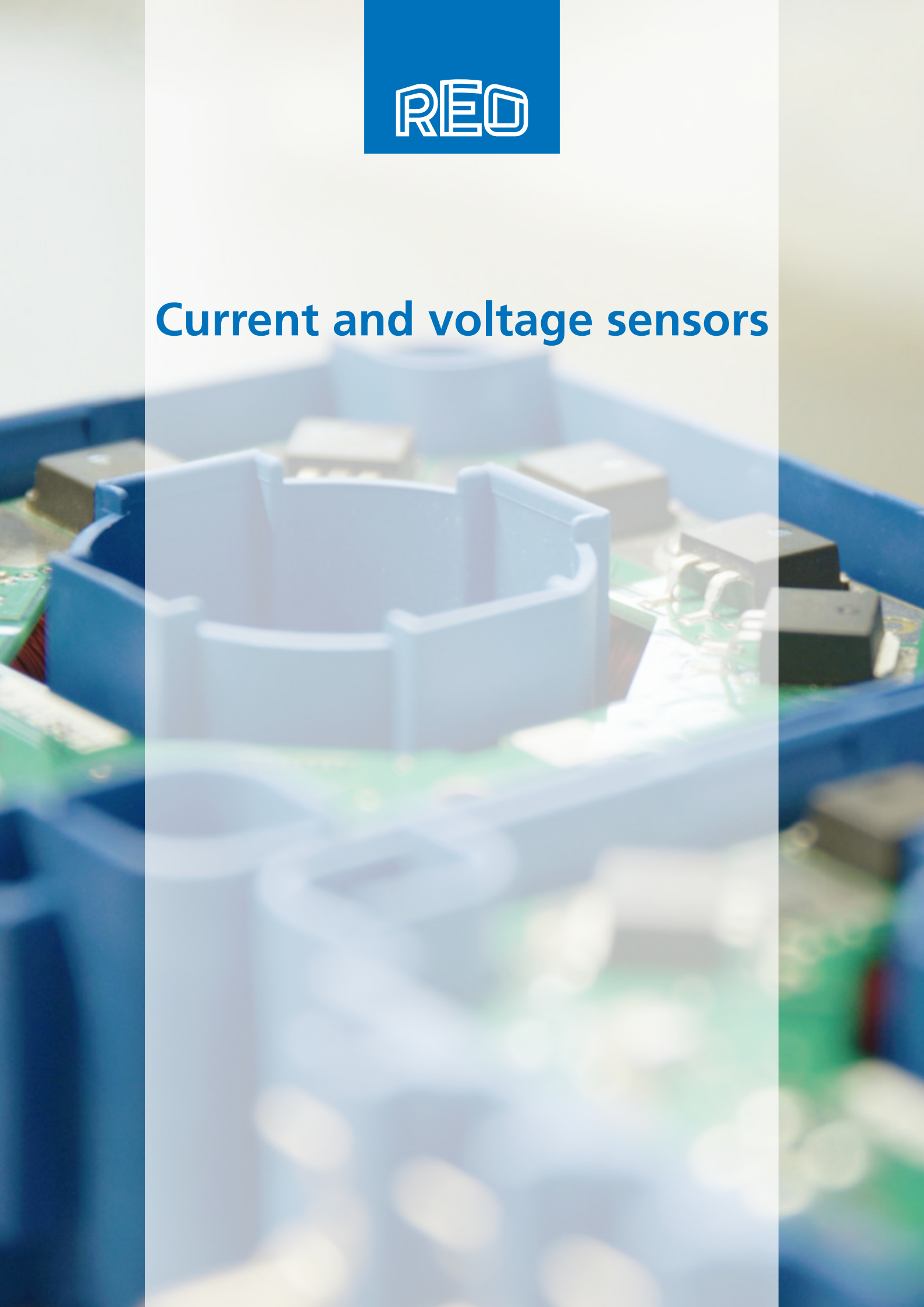

# Current and voltage sensors

Useful facts	P. 93
REO Double-Core Technology	P. 94
Overview	P. 95-97
WKO-2C / -2C-B	P. 98
WKO-2C	P. 99-103
WDI	P. 104-105
WKO	P. 106-107
IE	P. 108-109
IE modular	P. 110-111
IN	P. 112-113
IB 0,5	P. 114-115
IN-B	P. 116-117
IN-D	P. 118-119
IN-I	P. 120-121
Special solutions	P. 122

## Useful facts about current and voltage sensors

### A broad spectrum of REO transformers for individual applications

Particularly in the complex area of solar and wind and other the use of highly sophisticated power electronics. This feeds energy reliably into applications and keeps it precisely controlled and connected. These systems and other modern applications demand high quality current monitoring to ensure precise coordination between power semiconductors, system monitoring and mechanical engineering.

### From simple current monitoring to the efficient reduction of energy consumption

A broad spectrum of current and voltage transformers from REO provide solutions for a number of applications - for simple current monitoring or working within frequency converters, main and subsidiary current monitoring, and for the efficient reduction of energy consumption. A variety of technologies, such as open loop and closed loop technology, and the measurement of currents ranging up to 3000 A, ensure that the application can be optimized by using a sensor from REO.

### Low space requirement combined with outstanding performance

REO current transformers are particularly distinguished by their low space requirement, excellent linearity, fast response, and low iron and hysteresis losses.

Our current transformer designs are available for monitoring frequencies of up to 150 kHz and because of the tests performed before and during the production process (whether vacuum encapsulation, partial discharge measurements or high voltage testing) high reliability is ensured and are perfectly adapted to the application.

## REO - Double-Core Technology

In most applications, closed-loop current transducers deal with measurements in the range from DC to frequencies up to 150 kHz. For this application a standard single-core technology hall effect sensor mounted in the air gap is a good solution (see image 1). In this design, the hall effect sensor located in the air gap is used with a bipolar power stage to create an equal and opposite magnetic field in the core. This means that the current output signal is directly proportional to the primary current travelling in the conductor.

This principle works well for lower frequencies, but as frequencies increase the core inductivity becomes a larger factor and the compensating electronics are not able to work adequately. At this point, the unit acts like a conventional current transformer with poor linearity. This effect is demonstrated in image 2. This effect and subsequent lack of measurement accuracy are those facts which make the REO WKO 2C with double-core technology so important. The REO design team developed a solution to achieve a smooth, high accuracy transition from electronics to transformer-controlled domain.

We took two identical cores and joined them together as shown in image 3. This patented solution significantly improves measurement accuracy.

- Due to the compensation effect, the current transducer is insensitive to external magnetic fields.
- Better frequency response

REO's double-core frequency response in image 4 shows the smooth transition between electronics and transformer domains.

We have tested other current transducer technologies and we can safely say that only a few of them have acceptable smooth frequency transition performance as shown in image 5 below.

Image 1

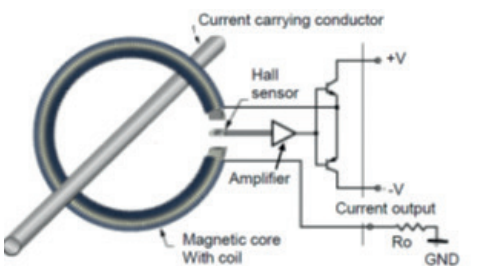

Image 2

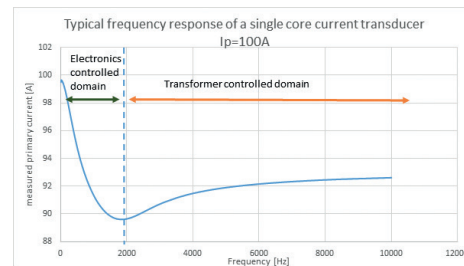

Image 3

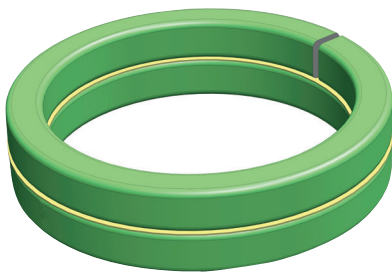

Image 4

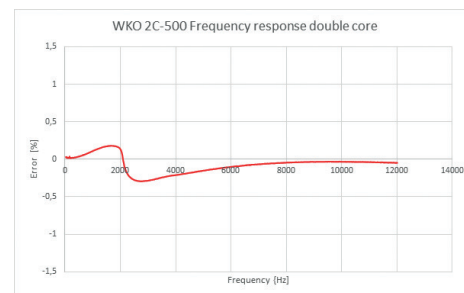
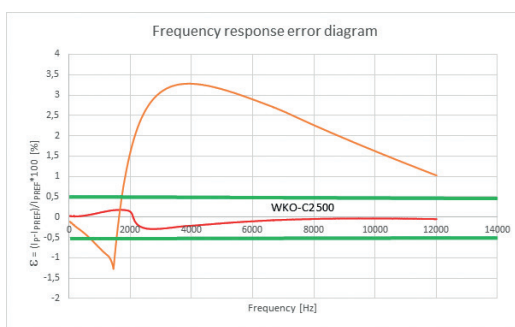

Image 5



## Overview industrial applications

### Areas of application

- Servo drives
- Static converters
- USV
- Welding equipment
- Plant monitoring in engine technology
- Forklift trucks
- Air-conditioning systems
- Lift technology

### Series WDI

- Primary current: 25 up to 500 A
- Frequency range: DC...10 kHz

### Series WKO

- Primary current: 25 up to 2000 A
- Frequency range: DC...150 kHz

### Series WKO-2C

- Primary current: 300 up to 2000 A
- Frequency range: DC...150 kHz

### Series IE

- Primary current: 1 up to 3000 A
- Frequency range: 50 up to 400 Hz

### Bunkering & Refilling

- Series VAREOTRON 166
- Series VAREOTRON MFR

### Series IB 0,5

- Primary current: 0 bis 40 A
- Frequency range: 50 up to 400 kHz

### Series IN

- Primary current: 1 up to 1000 A
- Frequency range: 0,05 up to 50 kHz

## Overview renewable energies

### Areas of application

- Wind-power engineering
- Solar technology
- Grid monitoring

### Series WDI

- Primary current: 25 up to 500 A
- Frequency range: DC...10 kHz

### Series WKO

- Primary current: 25 up to 2000 A
- Frequency range: DC...150 kHz

### Series WKO-2C

- Primary current: 300 up to 2000 A
- Frequency range: DC...150 kHz

### Series IN

- Primary current: 1 up to 1000 A
- Frequency range: 0,05 up to 50 kHz

### Series IN-D

- Residual current: 0,1 up to 10 A
- Frequency range: 0,05 up to 50 kHz

## Overview railway engineering

### Areas of application

- Main and subsidiary inverters for underground and surface trains
- Monitoring switching states
- Auxiliary converters
- Energy measurements
- Control measurements

### Series WDI

- Primary current: 25 up to 500 A
- Frequency range: DC...10 kHz

### Series WKO

- Primary current: 25 up to 2000 A
- Frequency range: DC...150 kHz

### Series WKO-2C

- Primary current: 300 up to 2000 A
- Frequency range: DC...150 kHz

### Series IE

- Primary current: 1 up to 3000 A
- Frequency range: 50 up to 400 Hz

### Series IN

- Primary current: 1 up to 1000 A
- Frequency range: 0,05 up to 50 kHz

### Series IN-B

- Primary current: 600 A
- Frequency range: 0,05 up to 50 kHz

## Overview metrology and testing techniques

### Areas of application

- Current matching
- Phase control
- Display devices
- Pulse measurement
- Network and plant protection
- Meters

### Series IN

- Primary current: 1 up to 1000 A
- Frequency range: 0,05 up to 50 kHz

### Series IN-I

- Primary current: 0 up to 200 A
- Frequency range: 0,05 up to 50 kHz

### Series IE

- Primary current: 1 up to 3000 A
- Frequency range: 50 up to 400 Hz

### Series IB 0,5

- Primary current: 0 up to 40 A
- Frequency range: 50 up to 400 kHz



# Overview energy, automation and building technology

## Areas of application

- Grid monitoring
- Overload relays
- Current relays
- Sensor monitoring
- Current measurement and monitoring
- Power supply shut-off
- Signal conversion
- Power control

## Series WDI

- Primary current: 25 up to 500 A
- Frequency range: DC...10 kHz

## Series WKO

- Primary current: 25 up to 2000 A
- Frequency range: DC...150 kHz

## Series WKO-2C

- Primary current: 300 up to 2000 A
- Frequency range: DC...150 kHz

## Series IE

- Primary current: 1 up to 3000 A
- Frequency range: 50 up to 400 Hz

## Series IB 0,5

- Primary current: 0 up to 40 A
- Frequency range: 50 up to 400 kHz

## Series IN

- Primary current: 1 up to 1000 A
- Frequency range: 0,05 up to 50 kHz

## WKO-2C / -2C-B

Active current transformers

REO has developed a new generation of closed-loop (C/L) current transducers which guarantee increased current measurement accuracy better than 0.3% in the whole frequency range: DC to 150 kHz.

The new current transducer type WKO-2C is a completely new development utilizing REO's double-core technology magnetic design. The unit uses the latest hall effect elements with an extended frequency response up to 150 kHz and accurate phase response.

Completely redesigned electronics ensures that the new C/L current transducer has better drift compensation and an extended temperature range from -40°C to 85°C.

Plug+Play  
Modular construction

- various mounting options through pluggable mounting feet and mounting kit for busbars
- 3 different connection options: Molex plugs, litz wires or litz wires with plug

- Through standardized design REO current sensors WKO-2C are compatible with conventional models available on the market – no modifications necessary
- Molex-22-29-2031
- JST-BH03B-XASK-BN High-Box Standard
- JST-BH3P-VH-1
- Bolted connection with faston connection
- stranded wire connection

WKO-2C-B  
Also available for railway applications

- Fulfills the required railway engineering safety standards: EN 50175, EN 50155:2007 and IEC 61373:2010
- Specially for railway technology: shock and vibration tested according to IEC 61373:2010
- Bolted connection with faston connection

## Advantages

- High current measurement accuracy of 0.3%
- Modular designs providing universal mounting options
- Lower sensitivity to external magnetic fields
- Bidirectional and isolated current measurement
- Current output
- REO double-core technology
- All materials used are UL listed

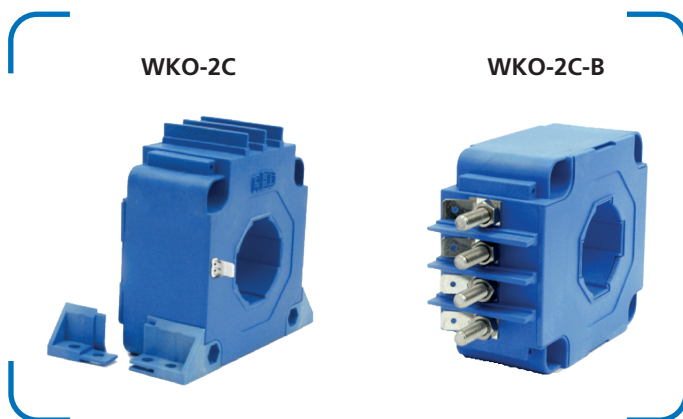

EN 50178: 1997  
UL 94-V0

## Technical data

WKO-2C								
Type	Primary RMS Nominal current $I_{PN}$ [A]	Measurement range $I_p$ [A]	Feed-in $U_c$ [V]	Measurement accuracy $X_G@I_{pn}$ [-20...70°C] of $I_{PN}$ [%]	Ratio $K_N$	Secondary RMS nominal current $I_{SN}$ [mA]	Secondary winding Resistor $R_s@85^\circ\text{C}$ [ $\Omega$ ]	No-load current [mA]
WKO-2C-300	300	0 ... $\pm 2000$	$\pm 11,4...25,2$	$< \pm 0,3$	2000	150	13	$26+I_s$
WKO-2C-500	500	0 ... $\pm 1000$	$\pm 11,4...25,2$	$< \pm 0,3$	5000	100	76	$26+I_s$
WKO-2C-1000	1000	0 ... $\pm 2700$	$\pm 14,25...25,2$	$< \pm 0,3$	5000	200	42	$26+I_s$
WKO-2C-2000	2000	0 ... $\pm 4000$	$\pm 14,25...25,2$	$< \pm 0,3$	5000	400	26	$26+I_s$

## Accuracy and dynamic data

WKO-2C							
Type	Linearity mistake $e$ [%]	Offset mistake@25° $I_o$ [mA]	Offset drift -25°C ... +70°C $I_{OT}$ [mA]	Reaction time $t_{ra}$ [ $\mu\text{s}$ ]	Response time 10%-90% $t_a$ [ $\mu\text{s}$ ]	dI/dt [A/ $\mu\text{s}$ ]	Stock width -1dB [kHz]
WKO-2C-300	$< \pm 0,1$	$\pm 0,5$	$< 25$	0,2	0,4	400	150
WKO-2C-500	$< \pm 0,1$	$\pm 0,5$	$< 25$	0,2	0,4	400	150
WKO-2C-1000	$< \pm 0,1$	$\pm 0,5$	$< 25$	0,2	0,4	400	150
WKO-2C-2000	$< \pm 0,1$	$\pm 0,5$	$< 25$	0,2	0,4	1000	150

## Isolation data

WKO-2C						
Type	Creepage distance $d_{Cp}$ [mm]	Clearance $d_{Ci}$ [mm]	Creep resistance [CTI]	AC-Isolation test 50/60Hz 1min $U_d$ [kV]	Impulse voltage test 1,2/50 $\mu\text{s}$ $U_i$ [kV]	Weight [kg]
WKO-2C-300	14	13	600	6	12,5	0,340
WKO-2C-500	14	13	600	6	12,5	0,260
WKO-2C-1000	20	18	600	6	12,5	0,700
WKO-2C-2000	35	30	600	6	12,5	1,600

Typical applications: Variable speed control of 3-phase AC motors and servo motor drives, industrial inverters, uninterruptable power supplies, all types of switched-mode power supplies, power supplies for welding applications

# WKO-2C

Active current transformers

## Mechanical Data

- Various mounting options with pluggable bases
- The multi-purpose mounting system means that the units can be used easily in new designs and in retro-fit applications
- Various connection possible

WKO-2C									
Type	b1 [mm]	b2 [mm]	t [mm]	s [mm]	h [mm]	D Ø [mm]	D1/D2 [mm]	Ø f [mm]	Ø e [mm]
WKO-2C-300	57	70	38	57	70	30,2	10,4/30,4	4,3	4,3
WKO-2C-500	57	70	38	57	70	30,2	10,4/30,4	4,3	4,3
WKO-2C-1000	78	94	42	78	94	38,5	13,5/40,5	5,3	5,3
WKO-2C-2000	102	135	52	102	135	57,5	20,5/60,5	6,5	6,5

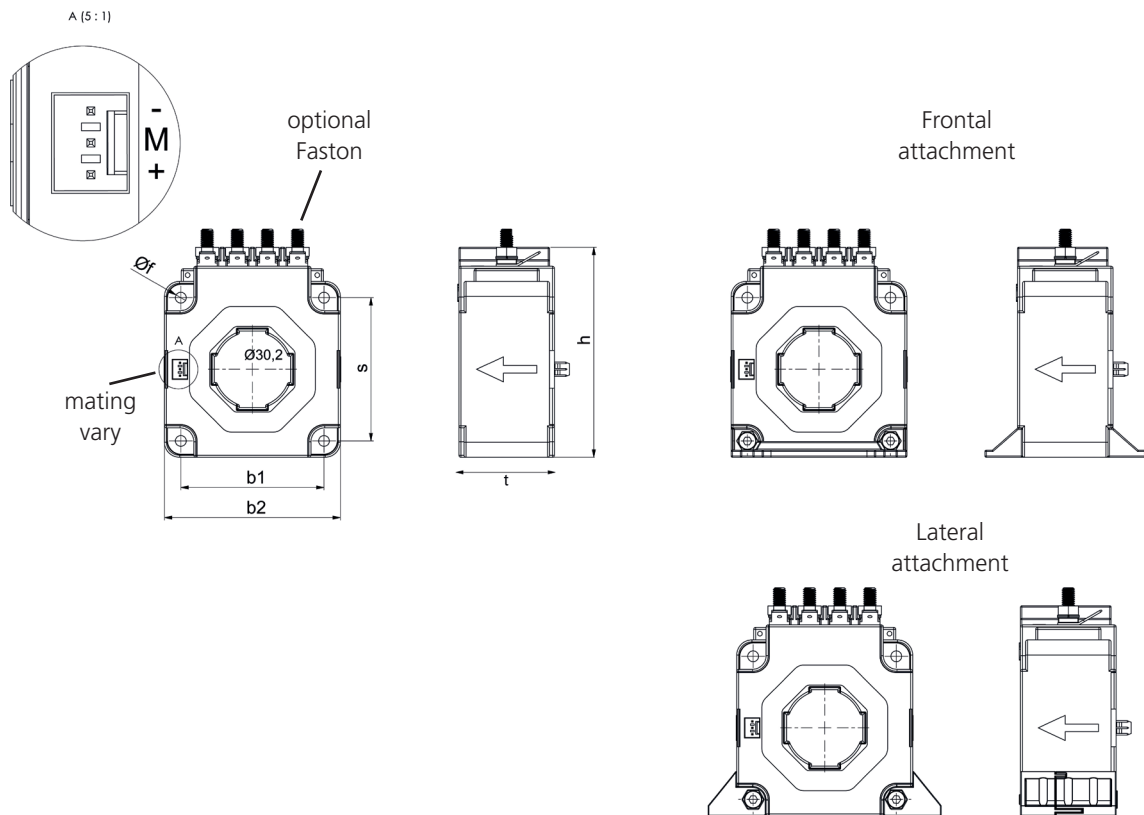

# WKO-2C

Active current transformers

**WKO-2C**  
Basic model with Molex plug



**WKO-2C-F**  
Basic model with Molex plug and mounting feet frontal



**WKO-2C-FG**  
Basic model with Molex plug and mounting feet frontal, fitted on the left

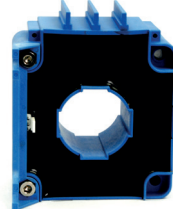

**WKO-2C-L**  
Basic model with Molex plug and mounting feet lateral

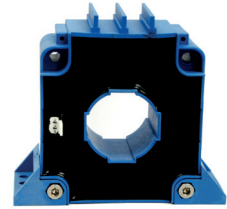

**WKO-2C-A**  
Basic model with front cover



**WKO-2C-A-F**  
Basic model with front cover and mounting feet frontal



**WKO-2C-A-L**  
Basic model with front cover and mounting feet lateral

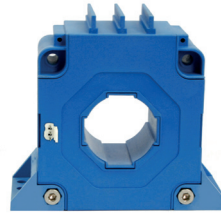

**WKO-2C-A-K**  
Model with front cover and litz wires

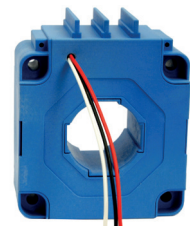

**WKO-2C-A-K-F**  
Model with front cover, litz wire and mounting feet frontal

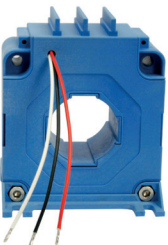

**WKO-2C-A-K-L**  
Model with front cover, litz wire and mounting feet lateral

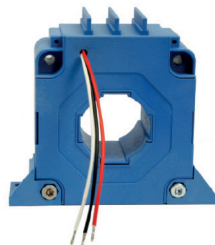

**WKO-2C-A-K-FG**  
Model with front cover, litz wire and mounting feet frontal fitted on the left

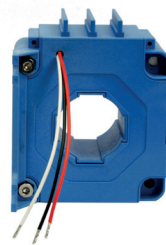

**WKO-2C-A-S-F**  
Model with front cover and litz wire with plug, with mounting feet frontal

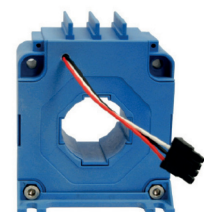

**WKO-2C-B**  
Basic model with Faston  
plugs and bolts and front  
cover



**WKO-2C-B-F**  
Basic model with Faston  
plugs, front cover and  
mounting feet frontal



**WKO-2C-B-L**  
Basic model with Faston  
plugs, front cover and  
mounting feet lateral



**WKO-2C-B-M**  
Basic model with faston  
plugs, pins and front  
cover as well as mounting  
attachment for conductor  
rail



**WKO-2C-B-M-F**  
Basic model with faston  
plugs, bolts, front cover  
and mounting attach-  
ment for conductor rail  
and mounting feet frontal



**WKO-2C-B-M-FR**  
Basic model with Faston  
plugs, front cover and  
mounting kit for busbar  
and mounting feet frontal,  
fitted on the right



**WKO-2C-B-M-L**  
Basic model with Faston  
plugs, front cover and  
mounting kit for busbar  
and mounting feet lateral



**WKO-2C-B-M-F-C**  
Basic model with Faston  
plugs, front cover and  
mounting kit for busbar  
and mounting feet frontal  
and busbar



## Fastenings optionally available for mounting to the basic model

**C**  
Copper busbar



**L**  
1 set of mounting feet  
lateral (2 left, 2 right)



**F**  
1 set of mounting feet  
frontal (2 pcs)



**A**  
Front cover



**M**  
Mounting kit for busbar



# WDI

Active current transformer

## Open loop current transformers

The WDI current sensor is an open loop current transformer designed for measuring direct and alternating currents. The primary current generates a magnetic flux and this is evaluated by means of a magnetic circuit and Hall sensor in the air gap.

The signal from the Hall sensor is processed by an electronic circuit and an exact representation of the primary current is output as a voltage.

### Advantages (electrical)

- Measurement of direct and alternating currents
- Voltage output
- Low power consumption
- No additional losses in the measuring circuit
- High-quality UL listed insulating materials (e.g. UL94-V0)
- Safe electrically isolated primary and secondary circuits
- Good price/performance ratio

### Advantages (mechanical)

- Low weight
- Assembly-friendly design
- Connections: clamps, plugs, flat-cable plugs or cables
- Wide range of housings with various push-through openings





# Technical data

WDI					
Type			25	150	300
Primary rated current [A]	$\hat{i}_{PN}$	Peak	25	150	300
Max. Primary rated current [A]	$\hat{i}_{maxPN}$	Peak	0 - $\pm 30$	0 - $\pm 180$	0 - $\pm 360$
Max. admissible output current [mA]	$\hat{i}_{outPN}$		$\pm 5$	$\pm 5$	$\pm 5$
Load resistance minimal [k $\Omega$ ]	RBmin	$\pm 15$ Vdc	$\pm 30A$ peak=2	$\pm 150A$ peak=2	$\pm 300A$ peak=2
				$\pm 180A$ peak=2	$\pm 360A$ peak=2
Load resistance maximal [k $\Omega$ ]	RBmax	$\pm 15$ Vdc	$\pm 30A$ peak=10	$\pm 150A$ peak=2	$\pm 300A$ peak=2
				$\pm 180A$ peak=2	$\pm 360A$ peak=2
RMS Rated output voltage [V]	$\hat{U}_{aN}$	Peak	$\pm 10$	$\pm 10$	$\pm 10$
Operation voltage [Vdc]	US	$\pm 5\%$	$\pm 15$	$\pm 15$	$\pm 15$
No-load current [mA]	IBO	(@ $\pm 15V$ ) + $i_{outPN}$	9	9	9
Insulation test voltage [kV]	VP	r.m.s 50 Hz	3	3	3
Voltage drop [kV]	VW	1,2/50 $\mu s$	3	5	5
Accuracy 50 Hz [%]	FU	@IPN, TA=25°C	$\pm 0,6$	$\pm 0,6$	$\pm 0,6$
Linearity error [%]	FLU	@TA=25°C	$\leq 1,0$	$\leq 1,0$	$\leq 1,0$
Offset voltage [mV]	Uo	@ IPN = 0, TA =25°C	20	20	20
Offset voltage drift [mV]	$\Delta U_o$	lo -25°C...+70°C	60	60	60
Temperature drift [%/K]	%/ $\Delta T$		$\leq 0,05$	$\leq 0,05$	$\leq 0,05$
Response time [ $\mu s$ ]	tr	@ 90% von IPN	<25	<25	<25
Frequency range [kHz]	f		(-3 dB) DC...10	(-3 dB) DC...10	(-3 dB) DC...10
Ambient temperature [°C]	TA		-25 to + 75	-0 to + 75	-0 to + 75
Storage temperature [°C]	Ts		-10 to + 85	-10 to + 85	-10 to + 85
Weight [kg]	m		0,075	0,075	0,075
Creepage distance [mm]	dCp		4	10	10
Clearance distance [mm]	dCi		3	9	9

Typical applications: Industry, renewable energy, railway engineering, energy, automation and building technology

## Dimensions in mm

WDI												
Type	PIN- Connection/ 4-pole	h [mm]	b [mm]	b1/b2 [mm]	t [mm]	DL [mm]	p/s [mm]	a/a1 [mm]	c1/c2 [mm]	f [mm]	e [mm]	l [mm]
WDI 25	A; O, -U; +U	39	39	-	26,5	10	-	3 x 10/6,5	25/6,5	M4	-	9
WDI 150	A; O, -U; +U	55	-	55/68	26	20,2	45/45	60/--	13,0/--	4,3	6,0 x 4,0	23
WDI 300	A; O, -U; +U	55	-	55/68	26	20,2	45/45	60/--	13,0/--	4,3	6,0 x 4,0	23

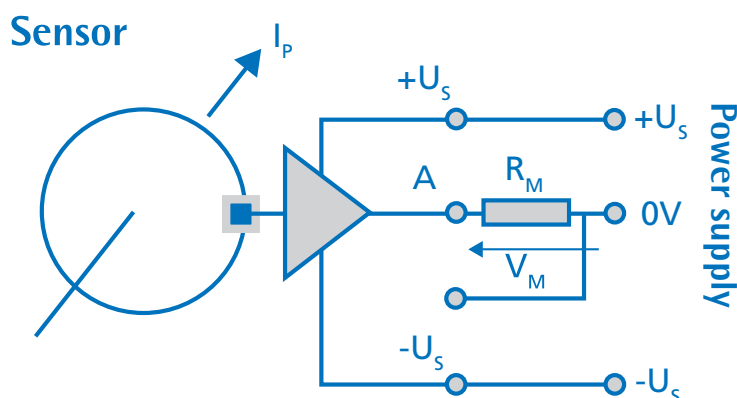

## Compensation current transformer (Closed loop current transformers)

WKO current sensors work in accordance with the proven compensation principle and are suitable for measuring direct, alternating and mixed currents. The primary current generates a magnetic flux, which is compensated by an internal

secondary coil. The current is evaluated by an electronic circuit and a Hall sensor. The secondary compensating current is a precise representation of the primary current to be measured.

### Advantages (electrical)

- Measurement of direct, alternating and mixed currents
- Very high precision and short response time
- Broad frequency spectrum and low temperature drift
- Very good linearity and overcurrent resistance
- No additional losses in the measuring circuit (DC to 150 kHz)
- Current output for lengthy transmission lines
- High-quality UL listed insulating materials (e.g. UL94-V0)

### Advantages (mechanical)

- Assembly-friendly design
- Variable connections, e.g. clamps, plugs, flat-cable plugs or cables
- Wide range of housings with various pushthrough openings

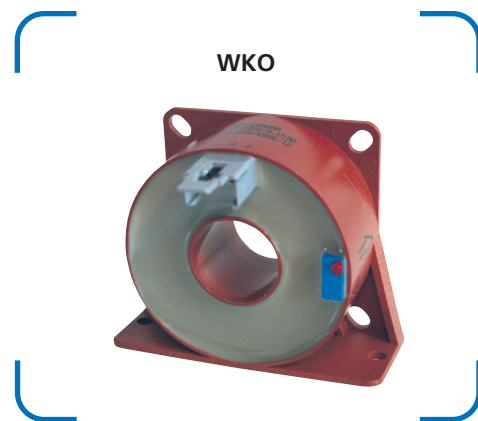

### Electrical data

WKO							
Type	WKO 25	WKO 50	WKO 100	WKO 300	WKO 500	WKO 1000	WKO 2000
Primary RMS Nominal current IPN [A]	25	50	100	300	500	1000	2000
Measurement range IP [A]	0 ... ±35	0 ... ±70	0 ... ±150	0 ... ±500	0 ... ±1000	0 ... ±1500	0 ... ±3000
Supply UC [V]	±12...15	±12...15	±12...15	±12...15	±12...24	±12...24	±12...24
Accuracy XG@I <sub>pn</sub> [-20...70°C] von IPN [%]	< ±0,9	< ±1	< ±1	< ±1	< ±1	< ±1	< ±1
Ratio KN	1000	1000	1000	2000	5000	5000	5000
Secondary RMS Nominal current ISN [mA]	25	50	100	150	100	200	400
Secondary winding current Resistance Rs@70°C [Ω]	16	43	24	30	72	48	27
No load Current [mA]	36+IS	11+IS	36+IS	36+IS	36+IS	24+IS	78+IS

## Accuracy and dynamic data

WKO							
Type	WKO 25	WKO 50	WKO 100	WKO 300	WKO 500	WKO 1000	WKO 2000
Linearity error $e$ [%]	< $\pm 0,1$	< $\pm 0,1$	< $\pm 0,1$	< $\pm 0,1$	< $\pm 0,1$	< $\pm 0,1$	< $\pm 0,1$
Offset error@25°C IO [mA]	< 0,3	< 0,3	< 0,4	< 0,2	< 0,2	< 0,3	< 0,5
Offset Drift -25°C ...+70°C IOT [mA]	< 0,5	< 0,5	< 1	< 0,5	< 0,5	< 0,5	< 0,5
Reaction time $t_{ra}$ [μs]	< 0,5	< 0,5	< 0,5	< 0,5	< 0,5	< 0,5	< 0,5
Response time 10%-90% $t_a$ [μs]	< 1	< 1	< 1	< 1	< 1	< 1	< 1
$dI/dt$ [A/μs]	> 50	> 50	> 100	> 100	> 100	> 100	> 100
Bandwidth -1dB [kHz]	DC...150	DC...200	DC...100	DC...100	DC...100	DC...100	DC...100

## Isolation data

WKO							
Type	WKO 25	WKO 50	WKO 100	WKO 300	WKO 500	WKO 1000	WKO 2000
Creepage path $d_{Cp}$ [mm]	4	8	10	10	10	15	25
Air path $d_{Ci}$ [mm]	3	7	9	9	9	12	21
Creepage Strength [CTI]	600	600	600	600	600	600	600
AC –Isolation test 50/60Hz 1min $U_d$ [kV]	3,8	3,8	3,8	3,8	6	6	6
Pulse voltage test 1,2/50μs $U_i$ [kV]	6	6	6	6	12,5	14,5	14,5
Measures [kg]	0,08	0,022	0,125	0,125	0,240	0,450	1,620



Typical applications: Industry, renewable energy sources, railway engineering, energy, automation and building technology

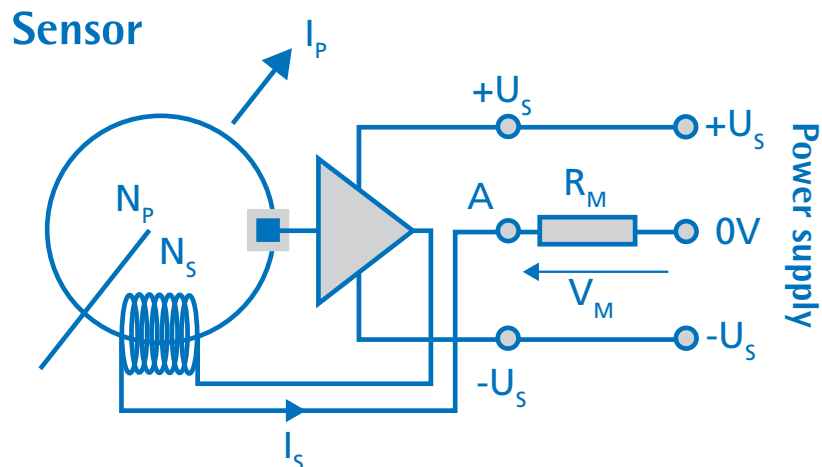

## IE

Passive current transformer

### Bushing-type current transformers

In the case of bushing-type current transformers, the customer's primary wire is pushed through the current transformer opening in the housing. The push-through opening depends on the size of the primary current. Wound primary type current transformers have a primary winding and a secondary winding. Both windings are applied on the closed toroidal core

and are isolated from each other by insulation. This principle applies mainly where primary currents are small. Low-voltage current transformers for the proportional transformation of large currents to directly measurable smaller current values

#### Advantages (electrical)

- Litz wires or terminals according to UL 94 V
- Bushing-type current transformers for direct conductor feedthrough
- Wound primary type current transformer, version for small currents
- Toroidal cores made of high-quality silicon-iron
- Measurement in the low frequency range 16 2/3 to -400Hz
- High core output power and high-quality insulation
- Electrically isolated primary and secondary circuits

#### Advantages (mechanical)

- Designs for easy installation
- Variable connections, e.g. clamps, plugs, flat-cable plugs, flexible stranded wire or print mounting
- Wide range of housings with various push-through openings
- Very long useful lifetime



## Technical data

IE								
Type		50	100	300	500	1000	2000	3000
Primary rated current [A]	$I_{pN}$	50	100	300	500	1000	2000	3000
Max. primary rated current [A]	$I_{maxPN}$	60	120	360	600	1200	2400	3600
Secondary current [mA]	$I_{aN}$	1000	1000	1000	1000	1000	1000	1000
Capacity [VA]	$P_{sek}$	0,5	1,0	2,5	10	15	25	25
Ratio	$K_N$	50	100	300	500	1000	2000	3000
Load resistance [ $\Omega$ ]	$R_B$	0,5	1,0	2,5	10	15	25	25
Load voltage [V]	$U_{RB}$	0,5	1,0	2,5	10	15	25	25
Measuring accuracy 50 Hz [%]	$F_U$	1,0	1,0	1,0	1,0	1,0	1,0	1,0
Ambient temperature [ $^{\circ}C$ ]	$T_A$	-25 to +70	-25 to +70	-25 to +70	-25 to +70	-25 to +70	-25 to +70	-25 to +70
Frequency [Hz]	f	50 to 400	50 to 400	50 to 400	50 to 400	50 to 400	50 to 400	50 to 400
Insulation test voltage [kVac]	$V_p$	3	3	3	3	3	3	3



Typical applications: Industry, renewable energy sources, railway engineering, energy, automation and building technology

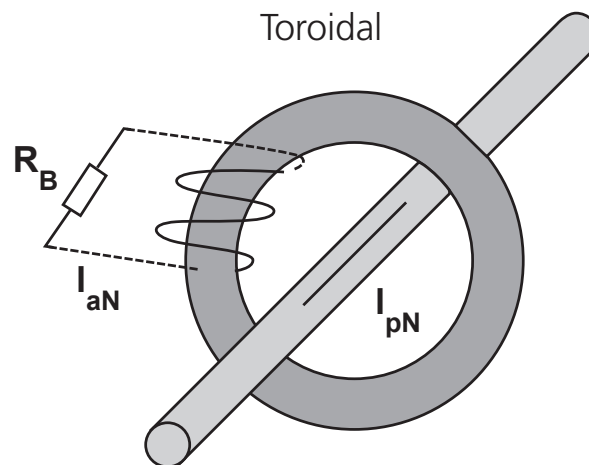

## IE modular

Passive current transformer

### A new REO development of AC current sensors in modular design

In the case of bushing-type current transformers, the customer's primary wire is pushed through the current transformer opening in the housing. The push-through opening depends on the size of the primary current. Wound primary type current transformers have a primary winding and a secondary winding. Both windings are applied on the closed toroidal core

and are isolated from each other by insulation. This principle applies mainly where primary currents are small. Low-voltage current transformers for the proportional transformation of large currents to directly measurable smaller current values.

### Advantages

- Bolts or flat plug connection
- Bushing-type current transformers for direct conductor feedthrough
- Toroidal cores made of high-quality magnetic cores
- Frequency range 16 2/3 to -400Hz optional
- High core output power and high-quality insulation
- Electrically isolated primary and secondary circuits
- Designs for easy installation
- Variable connections, e.g. clamps, plugs, flat-cable plugs, flexible stranded
- Wide range of housings with various push-through openings

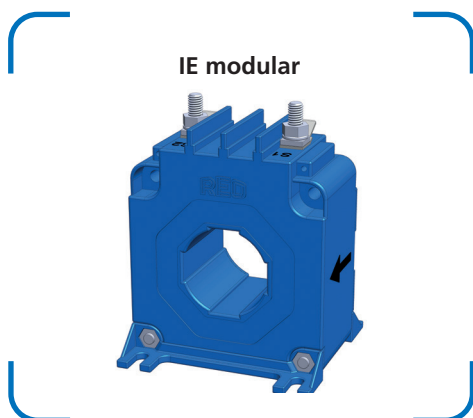

# Technical data

IE modular					
Type IE modular		500	1000	2500	
IPN	Primary rated current	500	1000	2500	[A]
ImaxPN	Max. primary rated current	600	1200	3000	[A]
IaN	Secondary current	1000			[mA]
RB	Load resistance	5	15	30	[Ω]
URB	Load voltage	5	15	30	[V]
PSek	Capacity	5	15	30	[VA]
KN	Transmission ratio	500	1000	2500	
Fi	Measuring accuracy [50 Hz]	0,5	0,5	0,5	[%]
f	Frequency	50 - 400			[Hz]
TA	Ambient temperature	-25 to +70			[°C]
Vp	Insulation test	3			[KVac]
Connection		MS Bolts/Flat plugs 6,3 x 0,8			[mm <sup>2</sup> ]
Weight		0,8	0,8	1,8	[kg]
Standards		61869-2			

Typical applications: Industry, renewable energy sources, railway engineering, energy, automation and building technology

## Dimensions in mm

IE modular										
Type	l [mm]	h1/h2 [mm]	t1/t2 [mm]	s1/s2 [mm]	b1/b2 [mm]	D [mm]	D1xD2 [mm]	f [mm]	e [mm]	x1/x2 [mm]
IE modular 500	70	76/35	38/64	57/57	57/50	30,2	30,4x10,4	4,3	4,3	36/15
IE modular 1000	94	100/47	42/72	78/78	78/60	38,5	40,5x13,5	5,3	5,3	36/15
IE modular 2500	135	141/67,5	52/88	102/102	102/70	57,5	60,5x20,5	6,5	6,5	36/15

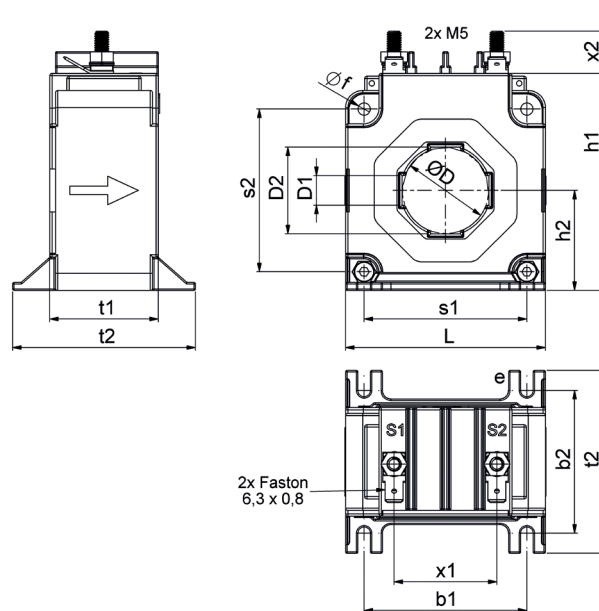

# IN

Passive Current transformer

## Instrument transformers

The growing development and spread of electronic devices with high working frequencies requires the use of current transformers with an extended frequency range.

This demand can be met with specially selected materials in conjunction with optimized design.

### Advantages (electrical)

- Electrical
- PIN connection according to UL 94 V-0
- Current transformers for precise current measurements
- Higher accuracy classes 1; 0,5; 0,2 than IE standard
- Measurements in the frequency range 16 2/3 to -50kHz
- Pulse measuring (e.g. 8/20 $\mu$ s)
- Low phase error for power measurement
- Very low hysteresis and Foucault current losses
- Nano-crystalline toroidal cores with strip thickness of 20 $\mu$ m for example
- Safe electrically isolated primary and secondary circuits

### Advantages (mechanical)

- Designs for easy installation
- Wide range of housings with various push-through openings

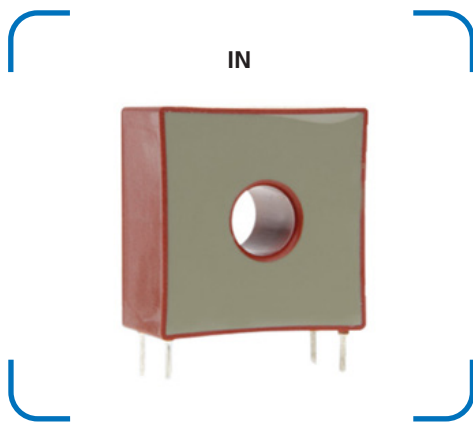



# Technical data

		IN					
Type		1	3	5	10	25	50
Primary rated current [A]	$I_{PN}$	1	3	5	10	25	50
Max. primary rated current [A]	$I_{maxPN}$	1,2	3,6	6	12	30	60
Secondary current [mA]	$I_{aN}$	20	20	20	20	25	50
Rated power [VA]	$P_{sek}$	0,05	0,05	0,05	0,05	0,063	0,25
Ratio	$K_N$	50	150	250	500	1000	1000
Load resistance [ $\Omega$ ]	$R_B$	125	125	125	125	100	100
Load voltage [V]	$U_{RB}$	2,5	2,5	2,5	2,5	2,5	5
Measuring accuracy 50 Hz [%]	$F_U$	$\leq 1$	$\leq 1$	$\leq 1$	$\leq 1$	$\leq 1$	$\leq 1$
Ambient temperature [ $^{\circ}C$ ]	$T_A$	-25 to +70	-25 to +70	-25 to +70	-25 to +70	-25 to +70	-25 to +70
Frequency [Hz]	f	0,05 to 50	0,05 to 50	0,05 to 50	0,05 to 50	0,05 to 50	0,05 to 50
Insulation test voltage Primary/Secondary / 2sec [kVac]	$V_P$	3	3	3	3	3	3
PIN Connection		3-4 / 2-1	3-4 / 2-1	3-4 / 2-1	3-4 / 2-1	NC/2-1	NC/2-1
Weight [kg]		0,05	0,05	0,05	0,05	0,05	0,07
Standards		EN/IEC 61869-1/2					



Typical applications: Industry, renewable energy sources, railway engineering, metrology and testing techniques, energy, automation and building technology

## Dimensions in mm

IN									
Type	Connection [mm <sup>2</sup> ]	h [mm]	b [mm]	t [mm]	DL [mm]	s [mm]	l [mm]	a [mm]	c [mm]
IN/1	3-4/2-1	34	33	18	9	1,0	3,5	27,5	10
IN/3	3-4/2-1	34	33	18	9	1,0	3,5	27,5	10
IN/5	3-4/2-1	34	33	18	9	1,0	3,5	27,5	10
IN/10	3-4/2-1	34	33	18	9	1,0	3,5	27,5	10
IN/25	NC/2-1	34	33	18	9	1,0	3,5	27,5	10
IN/50	NC/2-1	38	38	20	13	1,0	6,5	30	10

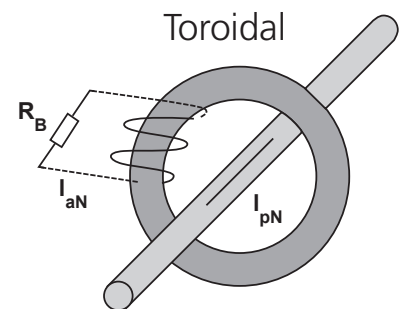
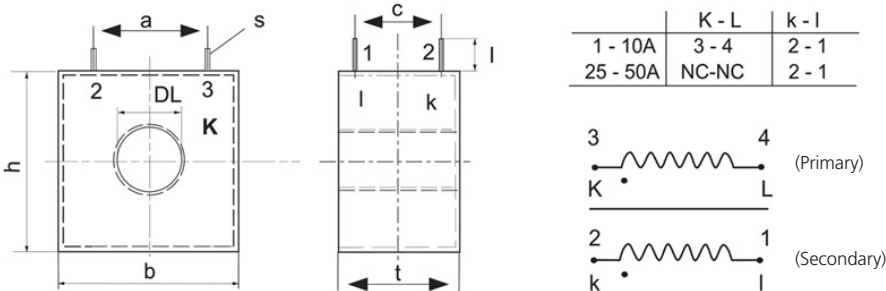

## IB 0,5

Passive Current transformer

### Instrument transformers

REO current transformers series IB are suitable for mounting on printed-circuit boards in the electric range of modern drive engineering for control purposes and measurement value logging.

### Advantages

- Low space requirement
- Suitable for PCB mounting
- Conforms to UL 94 V0
- Accuracy class 1
- Measurement in the frequency range 50-400 Hz
- Low phase error for power measurement
- Very low hysteresis and Foucault current losses
- Electrically isolated primary and secondary circuits
- Easy-to-install designs

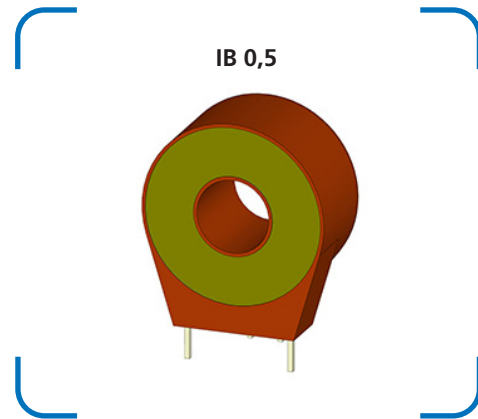

## Technical data

IB 0,5				
Type		IB 0,5/5	IB 0,5/20	IB 0,5/40
Primary rated current [A]	$I_{pN}$	0 - 5	0 - 20	0 - 40
Max. primary rated current [A]	$I_{maxPN}$	7	25	50
Secondary current [mA]	$I_{aN}$	0 - 10	0 - 25	0 - 40
Capacity [VA]	$P_{sek}$	0 - 0,010	0 - 0,025	0 - 0,040
Ratio	$K_N$	1:500	1:800	1:1000
Load resistance [ $\Omega$ ]	$R_B$	100	40	25
Load voltage [V]	$U_{RB}$	0 - 1		
Measuring accuracy 50 Hz [%]	$F_U$	$\leq 1$		
Ambient temperature [ $^{\circ}C$ ]	$T_A$	0..+85		
Frequency [Hz]	$f$	50 - 400		
Insulation test voltage [kVac]	$V_p$	3		



## Dimensions in mm

IB 0,5							
Type	Primary rated current [A]	Height [mm]	Width [mm]	Depth [mm]	Opening [mm]	PIN strength [mm]	PIN length [mm]
IB 0,5/5	0 - 5	30	26,5/17,5	14,5	10,5	0,7x0,7	5,0
IB 0,5/20	0 - 20	30	26,5/17,5	14,5	10,5	0,7x0,7	5,0
IB 0,5/40	0 - 40	30	26,5/17,5	14,5	10,5	0,7x0,7	5,0

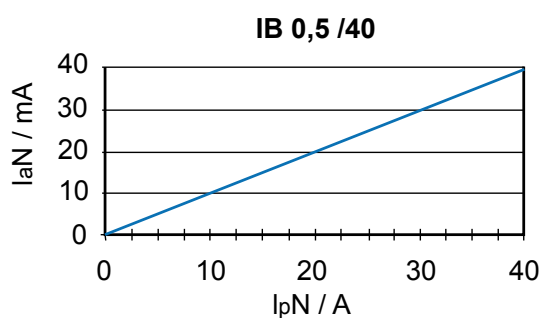
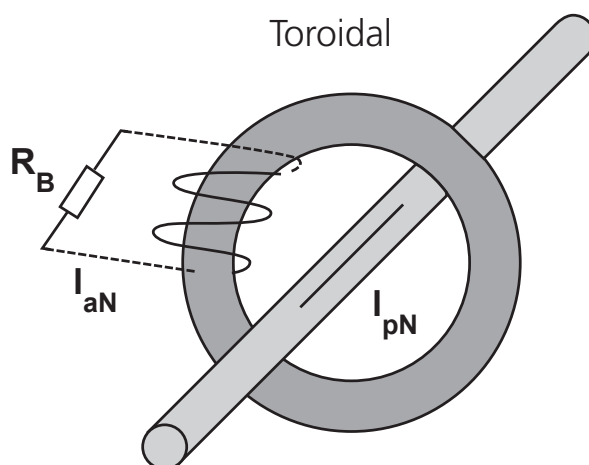

## IN-B

Passive current transformer

### Bushing-type and bar-type current transformers

For the high demands of railway and industrial engineering at higher frequencies up to 50kHz. High-quality nanocrystalline core materials guarantee the greatest degree of transmission quality and low losses. Exclusive use of UL-listed materials, fully sealed with UL94-V0 material. Current transformers for

demanding applications, such as in the railway sector and general transportation sectors. Robust housing construction with reliable securing options for vertical or horizontal mounting.

### Advantages

- High reliability
- Non-critical in the event of overload currents
- Current transformers for precise current measurements
- Measurements in the frequency range 16 2/3 to 50kHz
- Use of nanocrystalline and high-quality cores
- High-quality wires in temperature class F (155°C), H (180°C)
- High-quality UL listed insulating materials (e.g. UL94-V0)
- Safe electrically isolated primary and secondary circuits
- Assembly-friendly design (horizontal/vertical mounting)
- Shock and vibration tests in accordance with DIN EN 61373 Category 1 Class BB

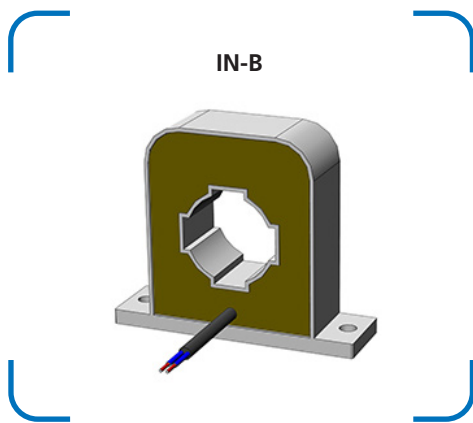

# Technical data

IN-B			
Primary rated current [A]	$I_{PN}$	r.m.s	600
Max. primary rated current [A]	$I_{maxPN}$	r.m.s	720
Secondary current [mA]	$I_{aIN}$	r.m.s	300
Rated power [VA]	$P_{sek}$		0,9
Ratio	$K_N$	1:	2000
Load resistance [ $\Omega$ ]	$R_B$		10
Voltage at load resistance [V]	$U_{RB}$	r.m.s	3
Measuring accuracy 50 Hz [%]	$F_U$	@ IPN, TA = 25°C	$\leq 1$
Ambient temperature [°C]	$T_A$		-25 to +70
Frequency [Hz]	f		0,05 to 50
Insulation test voltage Primary/Secondary/ 2sec [kVac]	$V_P$	r.m.s 50 Hz	3
Connection		3x0,5mm <sup>2</sup> with shield	cable
Storage temperature [°C]			-25 to +85
Secondary coil resistance [ $\Omega$ ]		@ TA = 25 °C	36,5
Weight [kg]			0,210
Standards			EN61373



Typical applications: Industry, renewable energy sources, railway engineering, metrology and testing techniques, energy, automation and building technology

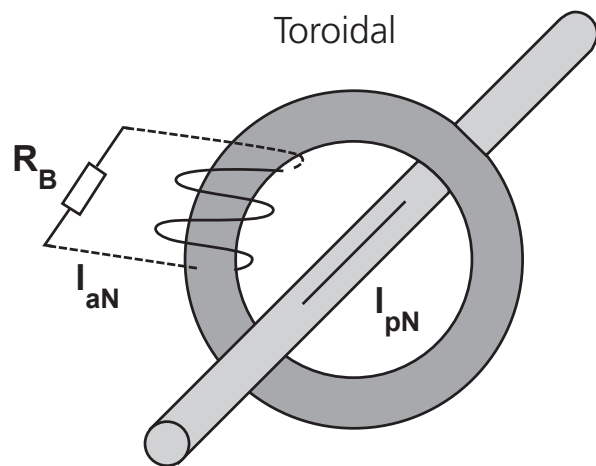
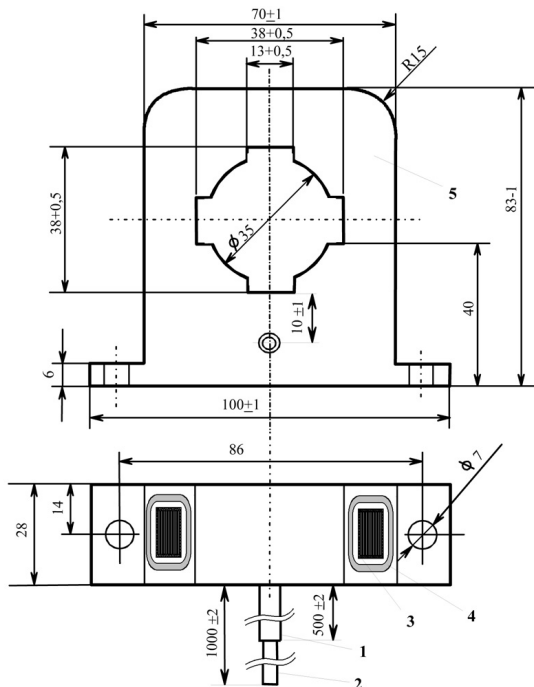

# IN-D

Passive current transformer

## Differential current transformers

A differential current transformer permits the measurement of differential current in single-phase or three-phase supply cables or in individual lines. Both current-carrying conductors (outward conductor and return conductor) are led through the current opening of the current transformer. The current measurement is performed by comparing the two conductors. Any difference is displayed at the output of the differential current transformer. The use of highly permeable materials permits a typical current deviation of 10 mA upwards.

The wide opening allows the supply lines, with the exception of the earthing conductor, to be led through directly. High sensitivity to current enables measurement in several stages:

- Stage 1: Notice of a malfunction
- Stage 2: Alarm
- Stage 3: Switching off

## Advantages

- Measurement from 25Hz to -400 Hz
- Use of nanocrystalline cores
- Current transformers for measuring
- High-quality UL listed insulating materials (e.g. UL94-V0)
- Safe electrically isolated primary and secondary circuits
- Assembly-friendly design (horizontal/vertical mounting)
- Variable connections
- Wide range of housings with various push-through openings
- Differential current range from 2 – 50 A

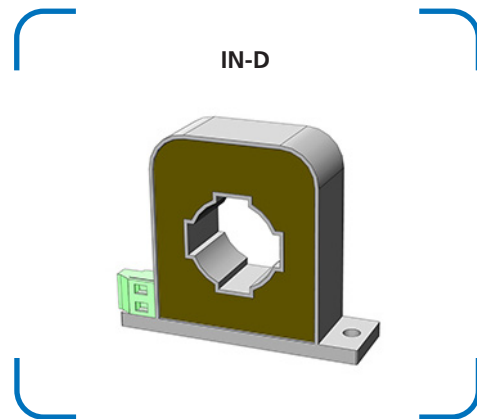

Housing 1

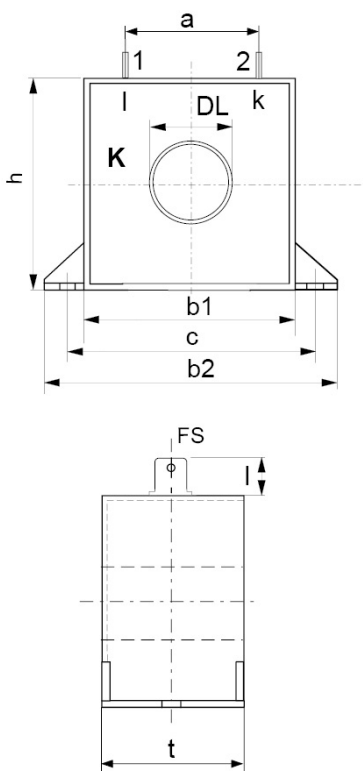

Housing 2

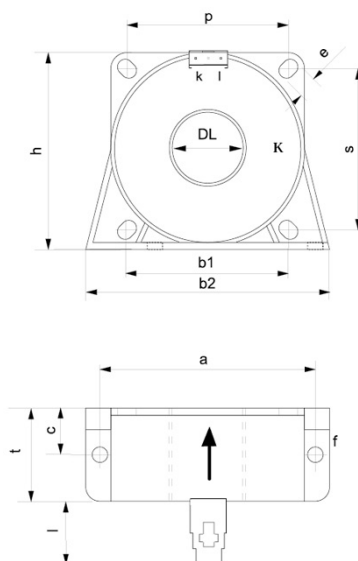

Housing 3

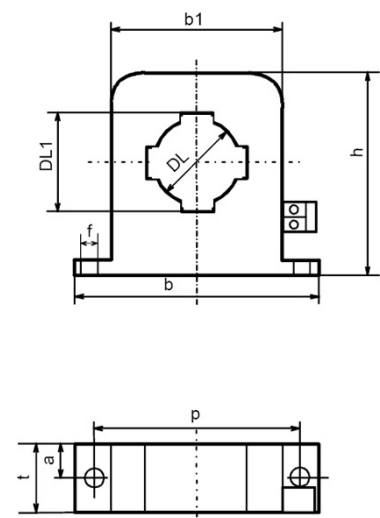

## Technical data

IN-D										
Type		2	4	8	29	30	40	30	40	50
		Housing A			Housing B			Housing C		
Primary rated current [A]	$I_{PN}$	0,1 - 1	0,1 - 2	0,1 - 4	0,1 - 10	0,1 - 10	0,1 - 10	0,1 - 10	0,1 - 10	0,1 - 10
Max. primary rated current [A]	$I_{maxPN}$	2	4	8	20	30	40	30	40	50
Thermal short-time current	ITK	0,5	0,5	0,5	3,6	3,6	3,6	9	9	9
Secondary current [mA]	$I_{aIN}$	2	4	4	20	10	5	20	16,67	10
Rated power [VA]	$P_{sek}$	0,004	0,008	0,016	0,030	0,030	0,015	0,06	0,05	0,06
Ratio	$K_N$	500	500	1000	500	1000	2000	500	600	1000
Load resistance [ $\Omega$ ]	$R_b$	1000	500	1000	75	300	600	150	180	600
Load voltage [V]	$U_{RB}$	2,0	2,0	4,0	1,5	3,0	3,0	3,0	3,0	6,0
Measuring accuracy 50 Hz [%]	$F_U$	$\leq 1$	$\leq 1$	$\leq 1$	$\leq 1$	$\leq 1$	$\leq 1$	$\leq 1$	$\leq 1$	$\leq 1$
Ambient temperature [ $^{\circ}C$ ]	$T_A$	-10 to +50	-10 to +50	-10 to +50	-10 to +50	-10 to +50	-10 to +50	-10 to +50	-10 to +50	-10 to +50
Frequency [Hz]	f	25 to 400	25 to 400	25 to 400	25 to 400	25 to 400	25 to 400	25 to 400	25 to 400	25 to 400
Insulation test voltage Primary/Secondary / 2sec [kVac]	$V_P$	3	3	3	3	3	3	3	3	3
Connection	A	Flat connection 6,3 x 0,8 / Plug MKS 1853 / Clamp 1,5 mm <sup>2</sup>								
Storage temperature	TS	-25 to +85	-25 to +85	-25 to +85	-25 to +85	-25 to +85	-25 to +85	-25 to +85	-25 to +85	-25 to +85
Coil resistance	RS	11	11	46	4,5	19	65	5,5	6,5	21
Weight	m	0,068	0,068	0,070	0,278	0,278	0,290	0,280	0,280	0,290
Standards		EN/IEC 61869-1/2								
Tracking resistance	CTI	Housing / resin 550/660M or 400/600M								
Creepage distance	dCp	18	18	18	8	8	8	18	18	18
Air distance	dCl	16	16	16	7	7	7	16	16	16



Typical applications: Industry, renewable energy sources, railway engineering, metrology and testing techniques, energy, automation and building technology

## Dimensions in mm

IN-D													
Type	Design	PIN- Connection [mm <sup>2</sup> ]	h [mm]	b1/b2 [mm]	t [mm]	DL/DL1 [mm]	FS [mm]	p/s [mm]	a [mm]	c [mm]	f [mm]	e [mm]	l [mm]
IN-D / 2	A	1 - 2	38	38 / 54	20	13 / -	6,3 x 0,8	-	30	47	4,8	-	9
IN-D / 4	A	1 - 2	38	38 / 54	20	13 / -	6,3 x 0,8	-	30	47	4,8	-	9
IN-D / 8	A	1 - 2	38	38 / 54	20	13 / -	6,3 x 0,8	-	30	47	4,8	-	9
IN-D / 20	B	MKS1853	55	50 / 68	26	20,2 / -	-	45 / 45	60	13	4,3	6 x 4,0	23
IN-D / 30	B	MKS1853	55	50 / 68	26	20,2 / -	-	45 / 45	60	13	4,3	6 x 4,3	23
IN-D / 40	B	MKS1853	55	50 / 68	26	20,2 / -	-	45 / 45	60	13	4,3	6 x 4,3	23
IN-D / 30	C	clamps	83	100 / 70	28	35 / 38	-	86 / -	14	-	7	-	-
IN-D / 40	C	clamps	83	100 / 70	28	35 / 38	-	86 / -	14	-	7	-	-
IN-D / 50	C	clamps	83	100 / 70	28	35 / 38	-	86 / -	14	-	7	-	-

# IN-I

Passive current transformer

## Pulsed current transformers

Because of the materials selected, REO pulsed current transformers in the IN-I series monitor current with high precision and in the appropriate transformation ratio - which makes them particularly suitable for power measurements, current monitoring and analysis, and for use in solar inverters. They are ideal for use in active filters, as they can be designed to measure current surges. The primary current is measured in a conductor fed through the closed toroidal core. The magnetic

field generated by the flow of current through the conductor is detected by the toroidal core, which, in accordance with the transformation ratio of the secondary winding, generates a smaller current for measurement purposes. By this means, a heavy current to be measured is reduced to a substantially smaller current and is in addition isolated from the primary circuit by safe electrical isolation.

## Advantages

- High-precision current measurements CI 0.2
- Pulsed current measurement
- Low-loss core (core losses <10W/kg at 20kHz/200mT)
- Housing made of UL-V0 material with inset thread
- Various applications e.g. for:  
Active filters, EMC measurements and pulse current measurements

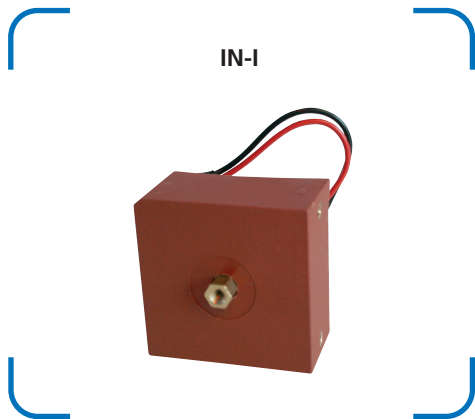



# Technical data

			IN-1		
Type			50	100	200
Primary rated current [A]	$I_{pN}$	r.m.s	0 - 50	0 - 100	0 - 200
Max. primary rated current [A]	$I_{maxPN}$	r.m.s	± 60	± 120	± 240
Secondary current [mA]	$I_{aN}$	r.m.s	0 - 50	0 - 100	0 - 200
Rated power [VA]	$P_{sek}$		0,5	1,0	1,5
Ratio	$K_N$	1:	1000	1000	1000
Load resistance [ $\Omega$ ]	$R_B$		200	100	37,5
Load voltage [V]	$U_{RB}$	r.m.s	10	10	7,5
Measuring accuracy 50 Hz [%]	$F_U$		± 0,2	± 0,2	± 0,2
Ambient temperature [°C]	$T_A$		-20 to +70	-20 to +70	-20 to +70
Frequency [Hz]	f		0,050 to 50	0,050 to 50	0,050 to 50
Insulation test voltage Primary/Secondary / 2sec [kVac]	$V_p$	r.m.s 50 Hz	3	3	3
Connection	A	Strands	150	150	150
Storage temperature	TS		-25 to +85	-25 to +85	-25 to +85
Coil resistance	RS	@ TA=25°C	11,5	11,5	9
Weight	m		0,270	0,270	0,270
Standards	EN/IEC 61869-1/2				
Tracking resistance	CTI	550 / 600M			
Creepage distance	dCp	10	10	10	
Air distance	dCl	9	9	9	



Typical applications: Metrology and testing techniques

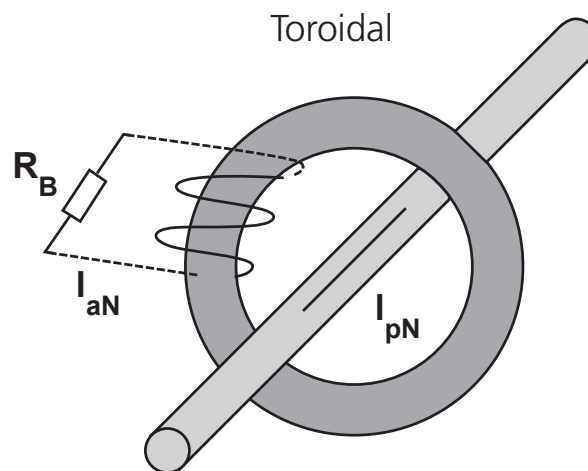
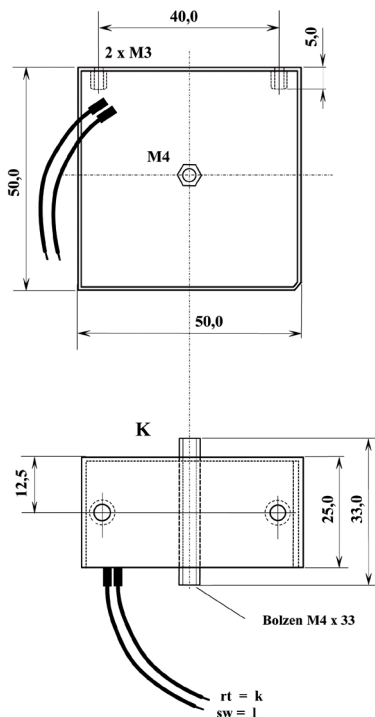

## Special solutions

Standard or individual product solution - also with small amounts

In addition to our wide standard product portfolio we can develop and manufacture your specific solution with the optimal performances you need.

Example:

New AC instrument transformer type IN05/500/5A-10VA-KI.0,2 with an accuracy of 0.2 (according to IEC 60044-1) combines the following advantages:

- Accuracy 0,2 %
- Load voltage 10VA
- Large push-through opening
- Insulation class II UL94V0
- According to IEC 60044-1

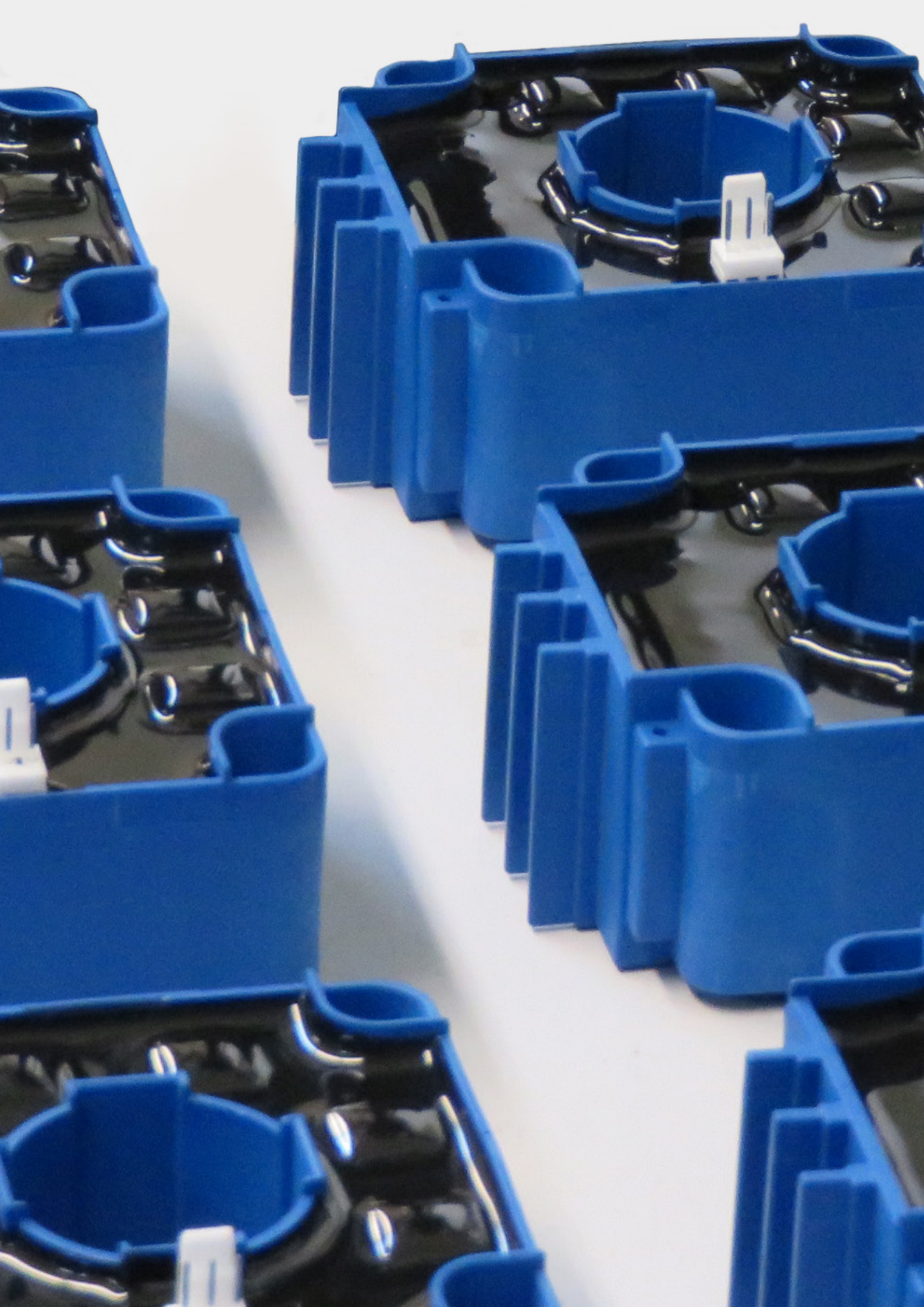



The logo for REO, consisting of the letters 'R', 'E', and 'O' in a stylized, white, sans-serif font. The 'R' and 'E' are connected at the top, and the 'O' is a simple circle. The logo is set against a solid blue rectangular background.

# HF-components



# HF-components

Useful facts	P. 127-129
HF transformers in various designs	P. 130
HF-Coldplate	P. 131
Useful facts about storage chokes	P. 132-133
Overview storage chokes	P. 134

## Useful facts about HF-components

In the design of HF systems the size of the components plays an important role. Transformers operating at frequencies above 50 Hz are usually much smaller than units operating at 50 Hz at comparable power levels. In addition undesirable characteristics such as eddy current losses and leakage inductance increase proportionally to the dimensions of the device so keeping the transformer small means that these unwanted characteristics are also reduced. The use of our core materials ensures that a high efficiency design with reduced costs and increased product life is possible. The switching frequency required by the customer plays an important role for the choice of core materials. The following core materials are used for REO transformers and chokes (depending on the frequency):

- Amorphous cores
- Nanocrystalline cores
- Ferrite cores

## Advantages

- Size reduction prolongs service life and enables cost savings
- Modular design
- Water cooling with Coldplate available
- Wide range of core materials and windings
- Insulation between primary and secondary windings for test voltages up to 6 kV
- Insulation for partial discharge  $\leq 10$  pC
- DIN EN 61287: 1-10 mm (Insulation distance between primary and secondary winding)
- Protection class up to IP 65 with litz wires and encapsulation
- Insulation class B, F and H
- Ambient temperature: -40 to +85°C
- Wide range of construction designs and options
- Customized solutions
- REOplus: REO speaks your language - with global sales offices and production REO is always close to its customers and can react quickly, efficiently and cost effectively

Depending on the calculation and application REO offers the following winding types:

- Stranded wire winding
- Wire winding
- Cu-strip

REO power transformers are available in plastic housings for industrial use (HF transformers for less demanding applications), mounted onto a plate with pins or in aluminium profile case. Full encapsulation and a wide range of winding types are further advantages of our transformers.



**Amorphous core material**

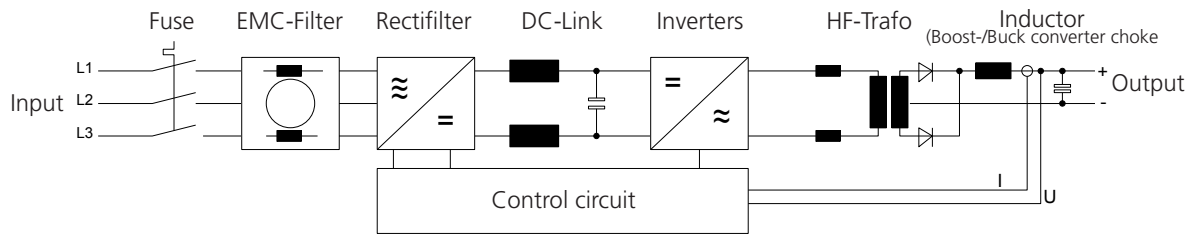

Switching principle forward converter

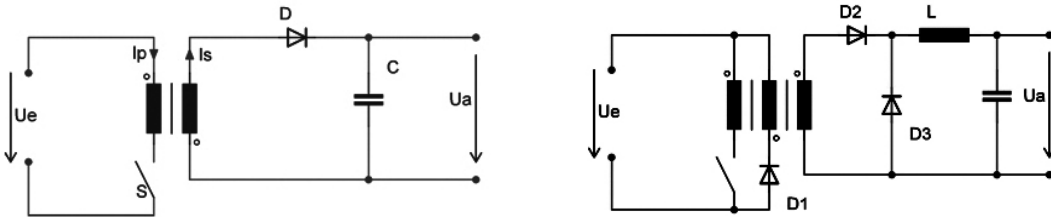

Switching principle half-bridge push-pull converter

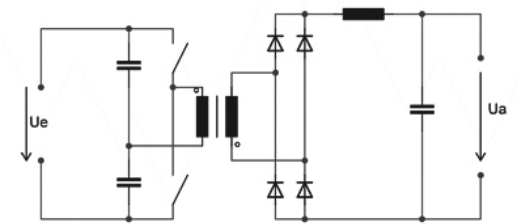

## Advantages HF wires

- High efficiency
- Suppression of the skin- and proximity-effect
- Minimal eddy current losses
- Prevention of „hot spots“
- High dielectric strength



### Suppression of the skin effect by HF wires

Alternating currents in all conductors naturally flow more easily near their surface. This skin depth is proportional to the frequency and power flowing. The magnetic field created by the flow of current, generates a current that opposes the main flow. This means that current only flows in the outer regions of the conductor effectively reducing its cross sectional area. This is known as the 'skin effect'. In HF wires the copper cross section is divided onto many small individual conductors. This ensures that the diameter of each conductor is less than the skin depth, so that the entire cross section for the current flow is available.

### Optional liquid cooling for HF transformers and chokes

REO's aluminium profile housing provides the possibility to mount the component onto a cooling plate (Coldplate) allowing further component optimization thanks to better heat dissipation. The cooling is carried out via cooling plates, which separate the cooling system physically from the electric circuit meaning that the electrically active components have no contact with the cooling medium.

### Competence and service down to the smallest detail

The most significant advantage of REO is the ability to design components for specific applications based on standard series. For us, service is not just a word: Specialized technicians and engineers develop customer specific product solutions. Product development, calculation and construction are made in close coordination with the customer at all stages of development.

All devices are available as standard design - but also as customer-specific solutions.

## Coldplate-Version

HF-transformers and chokes in aluminum profiles, mounted on a Coldplate can dissipate the heat more efficiently and can be integrated into existing systems.

- Example of a customized solution: Combination of filter chokes, boost converter and transformers, suitable for railway engineering and mounted on a Coldplate

## Coldplate-Choke CNW MC

- Targeted and optimized cooling
- Suitable for industrial water and standard cooling liquids
- Easy connection for liquid cooling
- Working pressure up to 4 bar (10bar test)
- Protection up to IP64
- Various connections: wires, terminals, terminal box
- Low audible noise
- Lower surface temperature

## HF transformers in various designs and with different core materials

### Advantages

- Smaller size due to high frequencies
- Less losses due to nanocrystalline, amorphous and ferrite cores
- Reduced use of materials
- Higher insulation class and less noises due to sealing technology
- Wide input voltage range possible, if  $U_{pmax} \cong 2x U_{pmin}$  is required.

### Connections

- Stranded wires with cable gland
- Copper connection bracket
- Brass stud bolt

**Design in plastic housing**  
Power: up to 10 kW

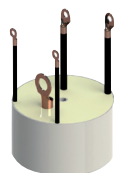

**Design in aluminium profile housing**  
Power: up to 30 kW

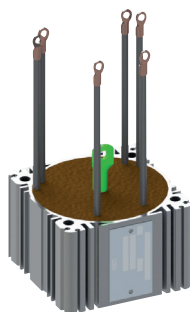

**Design in Aluminium folding housing**  
Power: up to 100 kW

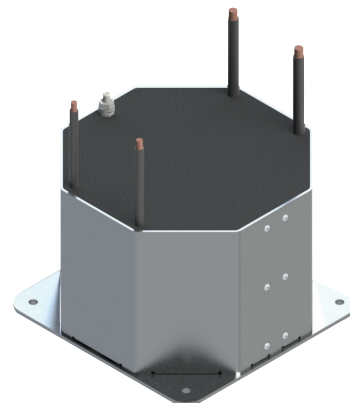

### Technical data

HF-transformers	
Power range:	1-100 kW
$U_{pmin}$ [V]:	190-685 V
$U_{pmax}$ [V]:	300-1800 V
$U_{sek}$ [V]:	32-900 V
Ü:	0,5-20
$I_{sek}$ [A]:	1,7-2x500 A

# HF-Coldplate

Coldplate-Version

REO's aluminium profile housing provides the possibility to mount the component onto a cooling plate (Coldplate) allowing further component optimisation thanks to better heat dissipation. The cooling is carried out via cooling plates,

which separate the cooling system physically from the electric circuit meaning that the electrically active components have no contact with the cooling medium.

## Advantages

- Reduction of product weight
- Separation of the cooling circuit from the electrical circuit
- Multiple combinations possible

Example of a design



## Overview storage chokes

### Design

- Design A = open design, low-profile (example: CHI 215 A)
- Design B = open design, upright
- Design C = housing, low-profile
- Design D = housing, upright
- Design E = housing, sealed with stranded wire
- Design F = socket, low-profile
- Design G = socket, upright
- Design H = aluminium housing, sealed with stranded wire
- Design J = aluminium profile

### Core materials

The following core materials are available for storage chokes, these are used for the complete range of the series:

- 1 = standard; iron powder (example: CHI 211 = series (21) + x (1) for the core material)
- 2 = Kool M $\mu$
- 3 = MPP
- 4 = HF
- 5 = Ferrit (with LS) (e.g. CHI 215)
- 6 = amorphous, nanocrystalline
- 7 = SiFe
- 8 = other

Design A, B

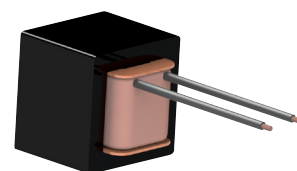
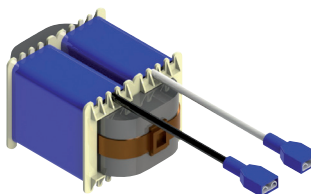
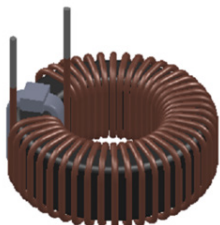

Design C, D

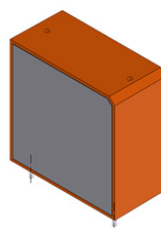
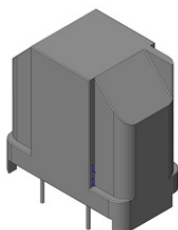
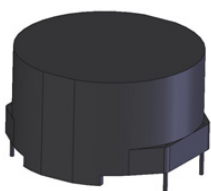

Design E

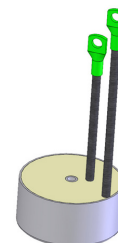

Design F, G

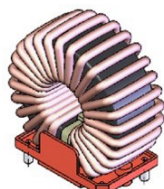
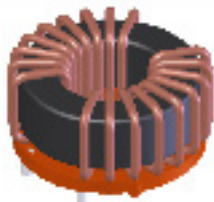

Design H

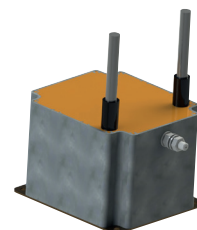
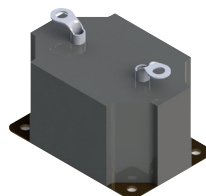

Design J

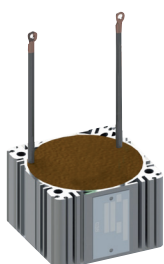

Switching principle boost converter choke:

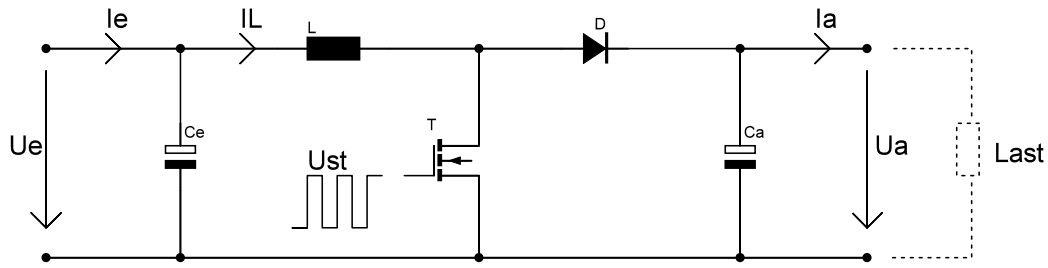

Switching principle buck converter choke:

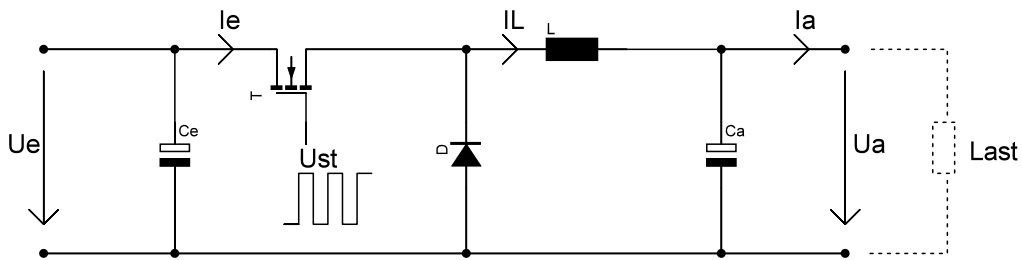

# Specification HF-Transformer

Reason for the request	
<input type="checkbox"/> Quote request	<input type="checkbox"/> Order

Specification HF-Transformer		
Type _____		
<b>Application</b>	<input type="checkbox"/> Single-ended forward converter	<input type="checkbox"/> Push-pull converter
<input type="checkbox"/> Flyback converter	<input type="checkbox"/>	<input type="checkbox"/> Circuit is attached
<b>Technical parameters</b>		
Input DC voltage*	$U_{min} =$ _____ V	$U_{min} =$ _____ V
Input current*	$I_E =$ _____ A	
Duty Cycle* ( $T = t_{on} / t_{off}$ )	$T =$ _____ max.	
Clock frequency* ( $f_p$ )	_____ kHz	
Voltage rise time	$=$ _____ mVs	
Output variable	Power	$P_A =$ _____ kW/W
	Voltage	$U_A =$ _____ V
	Current	$I_A =$ _____ A
Ambient temperature	$T_u =$ _____ °C	
Insulation class	_____	
<b>Mechanical parameters</b>	<input type="checkbox"/> Standard values	<input type="checkbox"/> Must be complied
Length: $l =$ _____ mm	Width: $b =$ _____ mm	Height $h =$ _____ mm
<b>Other details</b> (e.g. Test criteria, test voltage, standards)		
<b>Requirements planning</b> (e.g. specimen, pre-series, series, number of items)		

Contact details		
<b>Company:</b>		Date
<b>Contact person (tech.):</b>	Contact person (purchase)	Department
<b>Address:</b>		
City:		PLZ
Phone		Fax
Internet		E-Mail

\* Marked fields = mandatory fields, input required



REO AG  
Brühler Straße 100 · D-42657 Solingen  
Tel.: +49 (0)212 8804 0 · Fax: +49 (0)212 8804 188

E-Mail: [info@reo.de](mailto:info@reo.de)  
Internet: [www.reo.de](http://www.reo.de)



#### **DIVISIONS:**

##### **REO Vibratory Feeding and Power Electronics Division**

Brühler Straße 100 · D-42657 Solingen  
Tel.: +49 (0)212 8804 0 · Fax: +49 (0)212 8804 188  
E-Mail: [info@reo.de](mailto:info@reo.de)

##### **REO Train Technologies Division**

Erasmusstraße 14 · D-10553 Berlin  
Tel.: +49 (0)30 3670236 0 · Fax: +49 (0)30 3670236 10  
E-Mail: [zentrale.berlin@reo.de](mailto:zentrale.berlin@reo.de)

##### **REO Drives Division**

Holzhausener Straße 52 · D-16866 Kyritz  
Tel.: +49 (0)33971 485 0 · Fax: +49 (0)33971 485 90  
E-Mail: [zentrale.kyritz@reo.de](mailto:zentrale.kyritz@reo.de)

##### **REO Medical and Current Transformer Division**

Schuldholzinger Weg 7 · D-84347 Pfarrkirchen  
Tel.: +49 (0)8561 9886 0 · Fax: +49 (0)8561 9886 40  
E-Mail: [zentrale.pfarrkirchen@reo.de](mailto:zentrale.pfarrkirchen@reo.de)

##### **REO Test and PowerQuality Division**

Brühler Straße 100 · D-42657 Solingen  
Tel.: +49 (0)212 8804 0 · Fax: +49 (0)212 8804 188  
E-Mail: [info@reo.de](mailto:info@reo.de)

#### **PRODUCTION + SALES:**

##### **India**

REO GPD INDUCTIVE COMPONENTS PVT. LTD  
E-Mail: [info@reogpd.com](mailto:info@reogpd.com) · Internet: [www.reo-ag.in](http://www.reo-ag.in)

##### **USA**

REO-USA, Inc.  
E-Mail: [info@reo-usa.com](mailto:info@reo-usa.com) · Internet: [www.reo-usa.com](http://www.reo-usa.com)

#### **SALES:**

##### **China**

REO Shanghai Inductive Components Co., Ltd  
E-Mail: [info@reo.cn](mailto:info@reo.cn) · Internet: [www.reo.cn](http://www.reo.cn)

##### **France**

REO VARIAC S.A.R.L.  
E-Mail: [reovariac@reo.fr](mailto:reovariac@reo.fr) · Internet: [www.reo.fr](http://www.reo.fr)

##### **Great Britain**

REO (UK) Ltd.  
E-Mail: [main@reo.co.uk](mailto:main@reo.co.uk) · Internet: [www.reo.co.uk](http://www.reo.co.uk)

##### **Italy**

REO ITALIA S.r.l.  
E-Mail: [info@reoitalia.it](mailto:info@reoitalia.it) · Internet: [www.reoitalia.com](http://www.reoitalia.com)

##### **Poland**

REO CROMA Sp.zo.o  
E-Mail: [croma@croma.com.pl](mailto:croma@croma.com.pl) · Internet: [www.croma.com.pl](http://www.croma.com.pl)

##### **Spain**

REO ESPAÑA 2002 S.A.  
E-Mail: [info@reospain.com](mailto:info@reospain.com) · Internet: [www.reospain.com](http://www.reospain.com)

##### **Switzerland**

REO ELEKTRONIK AG  
E-Mail: [info@reo.ch](mailto:info@reo.ch) · Internet: [www.reo.ch](http://www.reo.ch)

##### **Turkey**

REO TURKEY ELEKTRONIK San. ve Tic. Ltd. Şti.  
E-Mail: [info@reo-turkey.com](mailto:info@reo-turkey.com) · Internet: [www.reo-turkey.com](http://www.reo-turkey.com)

##### **United Arab Emirates**

REO INDUCTIVE COMPONENTS FZCO  
E-Mail: [info@reo-middle-east.com](mailto:info@reo-middle-east.com)  
Internet: [www.reo-middle-east.com](http://www.reo-middle-east.com)